

16 MICROSTRIP LINE FILTERS

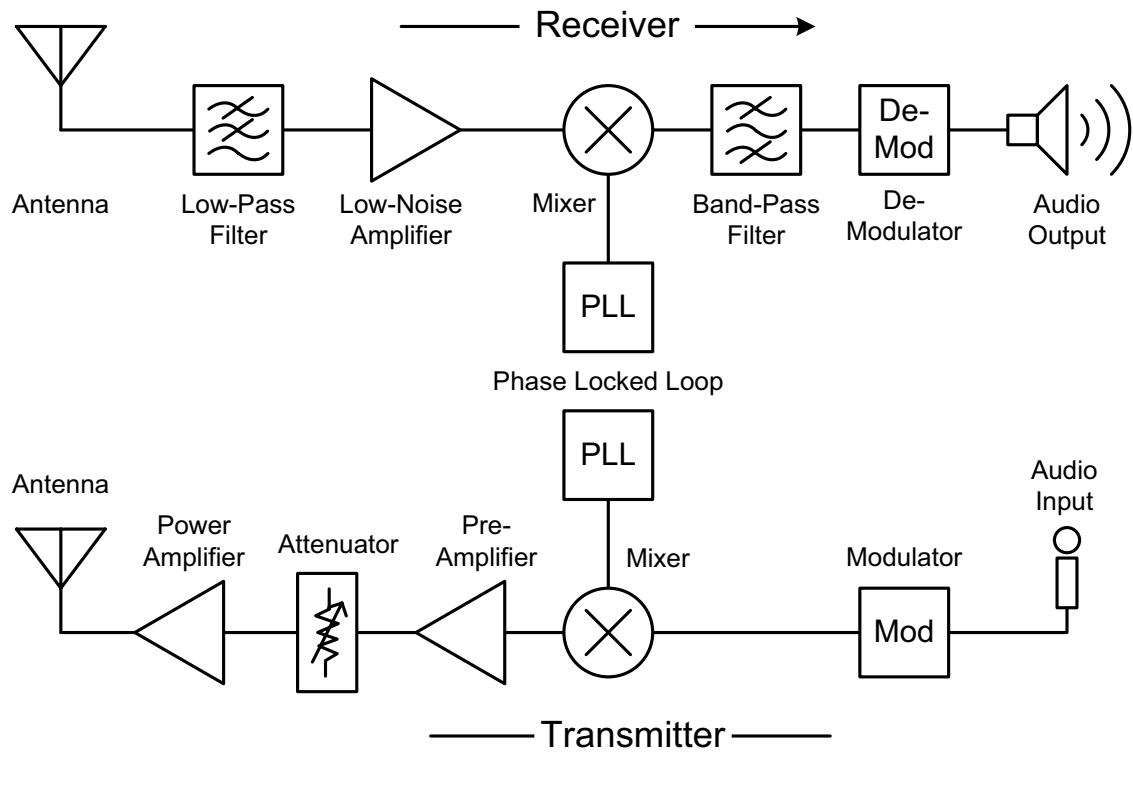

Objectives

1. Understand the basic concepts of microstrip line filters.
2. Learn how to design microstrip line filters.
3. Learn how to measure filter response.

* For generic filter and its applications, refer to Chapter 7.

Theory

When the signal frequency is high, for example 3GHz, the wavelength no longer becomes negligible as described in the generic circuit theory: in the example case, it reaches 100mm in free space. In other words, higher frequency has shorter wavelength. As the wave (signal) travels (flows) along the conductor, the phase of the voltage and current changes significantly over the physical length of the conductor. Therefore the conductor, which works as a short-circuit node in low frequency, now works as a “distributed component” in high frequency. It is a completely different conception from the standard circuit theory.

In this chapter we will introduce different methods to implement LPF, HPF and BPF by using the transmission line technique. The general filter related theory has been introduced in Chapter 7; here we will just focus on microstrip line filters.

16-1. Transmission Line Basics

Transmission line theory forms the basis of distributed circuits. For detailed study, we should start from Maxwell’s equations, then move on to electromagnetic wave analysis, and so on. In this section, we will give the very basic concept of transmission line since introducing everything in this textbook is impossible.

The key difference between circuit theory and transmission line theory lies in electrical size. The theory of circuit analysis assumes that the physical dimensions of a network are much smaller than its electrical wavelength; the size of transmission lines may be a fraction of single or several wavelengths. Thus we can say that a transmission line is a distributed-parameter network where voltages and currents can vary in magnitude and phase over the length of the network.

On the other hand, lumped elements in generic electronic circuit such as inductors and capacitors are generally available only for a limited range of values and are difficult to implement at microwave frequencies, where distance between filter components is not negligible.

The transmission line is often represented as shown in Figure 16-1.

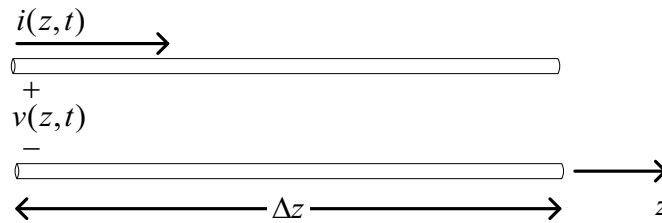

Figure 16-1, voltage and current definitions of a transmission line

In Figure 16-1, the voltage and current are not only functions of t (time) but also functions of z (position), which means the voltage and current will change at different positions (different spots of Z- axis). The equivalent circuit is shown in Figure 16-2.

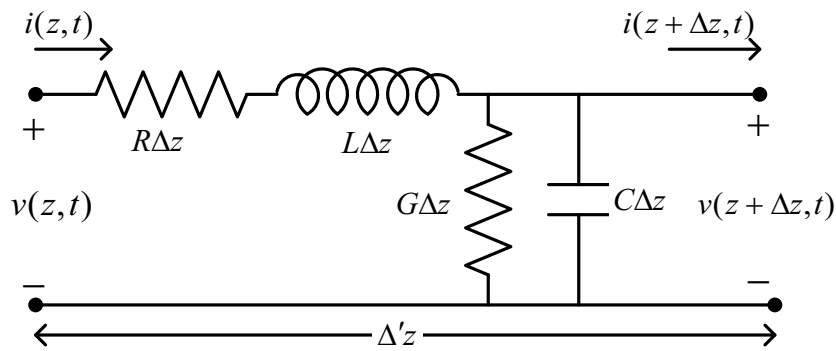

Figure 16-2, equivalent circuit of a transmission line

- R=series resistance per unit length, for both conductors, in Ω/m.
- L=series inductance per unit length, for both conductors, in H/m.
- G=shunt conductance per unit length, in S/m.
- C=shunt capacitance per unit length, in F/m.

The series inductance L represents the total self-inductance of the two conductors, while the shunt capacitance C occurs due to the close proximity of the two conductors. The series resistance R represents the resistance due to the finite conductivity of the conductors, while the shunt conductance G occurs due to dielectric loss in the material between the conductors R and G. A finite length of transmission line can be viewed as a cascade of sections formed as in Figure 16-2.

16-1-1. Wave Propagation on a Transmission Line

From Figure 16-2, we define the traveling wave as:

$$V(z) = V_o^+ e^{-\gamma z} + V_o^- e^{\gamma z} \quad (16-1)$$

$$I(z) = I_o^+ e^{-\gamma z} + I_o^- e^{-\gamma z} \quad (16-2)$$

the complex propagation constant as:

$$\gamma = \alpha + j\beta = \sqrt{(R + j\omega L)(G + j\omega C)} \quad (16-3)$$

The characteristic impedance Z_o can be defined as:

$$Z_o = \frac{V_o^+}{I_o^+} = \frac{V_o^-}{I_o^-} = \frac{R + jL}{\gamma} = \sqrt{\frac{R + j\omega L}{G + j\omega C}} \quad (16-4)$$

From the electromagnetic theory, we know:

$$v_p = \frac{dz}{dt} = \frac{1}{\sqrt{\mu\epsilon}} \quad (16-5)$$

where μ is the permeability and ϵ is permittivity of the medium. In free space, we have $v_p = 1/\sqrt{\mu_o\epsilon_o} = c = 2.998 \times 10^8 \text{ m/sec}$, which is the speed of light..

For the transmission line, the phase velocity is

$$v_p = 1/\sqrt{\mu_o\epsilon_o\epsilon_r}, \quad (16-6)$$

ϵ_r is the relative permittivity, also known as dielectric constant of the medium (substrate of the PCB).

We can find the wavelength as:

$$\lambda = \frac{v_p}{f} \quad (16-7)$$

and the wave number:

$$\beta = \frac{f}{\lambda} = 2\pi/\lambda \quad (16-8)$$

where α is the attenuation constant, and β is the wave number.

16-1-2. Lossless Line

The above solution is intended for general transmission line including loss effects, where the propagation constant and characteristic impedance are complex. However in many practical cases, the loss of the line is very small and can be neglected, allowing simplification of the above results. Setting $R=G=0$ in (16-3) gives the propagation constant as:

$$\gamma = \alpha + j\beta = j\omega\sqrt{LC} \quad (16-9)$$

$$\beta = \omega\sqrt{LC} \quad (16-10)$$

$$\alpha = 0 \quad (16-11)$$

16-1-3. Terminated Lossless Transmission Line

Figure 16-3 shows a lossless transmission line terminated by an arbitrary load impedance Z_L . This diagram illustrates the wave reflection problem in transmission lines, a fundamental property of distributed systems.

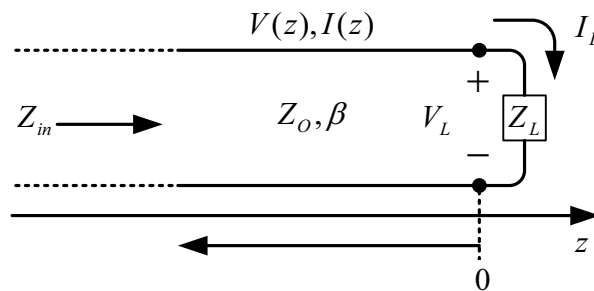

Figure 16-3

Assuming that a wave in the form $V_0^+ e^{-j\beta z}$ is generated from a source at $z < 0$, we can see that the ratio of voltage to current for such traveling wave is Z_0 , the characteristic impedance. But when the line is terminated in an arbitrary load $Z_L \neq Z_0$, the ratio of voltage to current at the load must be Z_L . Thus, to satisfy this condition, a reflected wave must be excited with the appropriate amplitude.

The amplitude of the reflected voltage wave normalized to the amplitude of the incident voltage wave is known as the voltage reflection coefficient Γ , expressed as:

$$\Gamma = \frac{V_o^-}{V_o^+} = \frac{Z_L - Z_o}{Z_L + Z_o} \quad (16-12)$$

When load mismatch occurs, not all generated power is delivered to the load. This “loss” is called Return Loss (RL), and is defined (in dB) as

$$RL = -20 \log|\Gamma| \text{ dB} \quad (16-13)$$

$$SWR = \frac{V_{\max}}{V_{\min}} = \frac{1 + |\Gamma|}{1 - |\Gamma|} \quad (16-14)$$

The general form of the input impedance in Figure 16-3 is described as follows.

$$\begin{aligned} Z_{in} &= Z_o \frac{(Z_L + Z_o)e^{j\beta l} + (Z_L - Z_o)e^{-j\beta l}}{(Z_L + Z_o)e^{j\beta l} - (Z_L - Z_o)e^{-j\beta l}} \\ &= Z_o \frac{Z_L \cos \beta l + jZ_o \sin \beta l}{Z_o \cos \beta l + jZ_L \sin \beta l} \\ &= Z_o \frac{Z_L + jZ_o \tan \beta l}{Z_o + jZ_L \tan \beta l} \end{aligned} \quad (16-15)$$

16-1-4. Special Cases of Terminated Lossless Lines

When a line is terminated in a short circuit, Z_L becomes $Z_L = 0$. From 16-15 Z_{in} is:

$$Z_{in} = jZ_o \tan \beta l \quad (16-16)$$

When a line is terminated in an open circuit, from 16-15 Z_{in} is:

$$Z_{in} = -jZ_o \cot \beta l \quad (16-17)$$

When the line length is $\lambda/2$:

$$Z_{in} = Z_L \quad (16-18)$$

When the line length is $\lambda/4$:

$$Z_{in} = \frac{Z_o^2}{Z_L} \quad (16-19)$$

Referring to 16-19 and redrawing Figure 16-3 as Figure 16-4, we get:

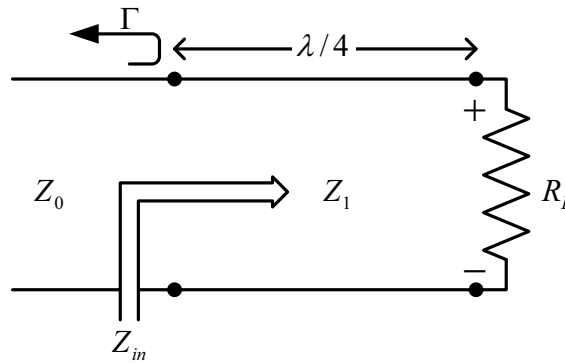

Figure 16-4

Z_L is composed of a transmission line of characteristic impedance Z_1 and R_L . In order for Γ to become 0, we also need $Z_{in}=Z_0$. The 16-13 shows the characteristic impedance as:

$$Z_1 = \sqrt{Z_o R_L} \quad (16-20)$$

Which is called Quarter-wave matching transformer.

16-1-5. Simulation Tools

The current simulation software tools are very useful for the designers, since they can save lot of time for complicated calculations. Many tools are available meeting a variety of demands. AppCAD developed by Agient (HP) is one of the tools for calculating transmission line parameters, and it can be downloaded from the public domain. The other software, like ADS and Momentum (by Agilent), MW Office (by AWR), HFSS and Symphony (by Ansoft) etc., can simulate the design of a circuit so that the designer can calculate the ideal results rapidly. Using the “Optimization” function in the software, the circuit design can be automatically tuned to meet the target specifications.

16-1-6. Suggestions and Reference of Microstrip Line Filters

The suggested steps of implementing microstrip line filters are as follows.

4. Find the L, C values according to the standard filter theory.
5. Convert the L, C to microstrip lines.
6. Construct and simulate the filters.
7. Fine tune and modify the design until the goal is met.
8. Fabricate the filters.

When fabricating the RF circuit on the PCB, the substrate material is a key factor for the success. Usually the FR4 material is not suited for frequencies above 1GHz because of the following reasons: the dielectric constant is not uniform over the whole material, the dielectric constant also varies according to frequency change, most circuit board suppliers can guarantee dielectric constant within a range but not at a precise value, etc. In practice, microwave substrate PCB such as ceramic and duroid[®] substrates is the better choice for microwave applications. In our experiment, FR4 is chosen because it is easier to obtain. The results may contain a margin of error, but the basic concept can definitely be established.

The main theory reference of this chapter is the following textbook: ‘Microwave Engineering’, by David, M. Pozar, *Addison-Wesley Publish Company, Inc.*.

16-2. Stepped -Impedance Low Pass Filter

A common way to implement a low pass filter is to use alternating sections of very high and very low characteristic impedance lines, which is referred to as stepped -impedance, or hi-Z / low-Z filter.

16-2-1. Design Example

Design a stepped-impedance type Butterworth low pass filter with cutoff frequency at 2GHz and > 20dB attenuation at 3GHz. The input and output impedance are both 50Ω. The PCB material is FR4 with dielectric constant 4.2 and thickness 1.2mm.

16-2-2. Solution

Referring to Table 7-5, since $\omega/\omega_c=1.5$ 20dB attenuation is 20dB at 3GHz, the order becomes 7. From Table 7-1, we find the normalized values of g_1 to g_8 as follows:

- $g_1=g_7=0.4450$
- $g_2=g_6=1.2470$
- $g_3=g_5=1.8019$
- $g_4=2.0000$
- $g_8=1.0000$

The equivalent circuit is illustrated in Figure 16-5.

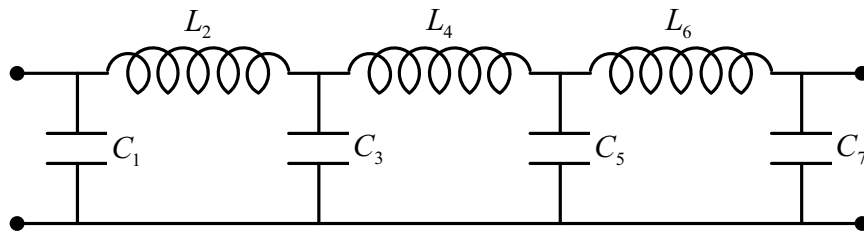

Figure 16-5

We then convert the L, C value to electronic length by the following equations:

$$\beta l = LR_o/Z_h, \text{ for inductor} \quad (16-21)$$

$$\beta l = CZ_l/R_o, \text{ for capacitor} \quad (16-22)$$

R_o is the filter impedance, β is the wave number, l is the line length, L and C are the normalized values, Z_h and Z_l are the highest and lowest line impedance, respectively.

According to Figure 16-3, g_1, g_3, g_5 and g_7 are capacitor sections in Z_l , and g_2, g_4 and g_6 are inductor sections in Z_h .

The PCB substrate is 1.2 mm thick, FR4 material, $\epsilon_r=4.4$. In order to make the PCB fabrication realistic, the line widths are adjusted to 0.5mm for Z_h and 5mm for Z_l before we start designing. The item left to be designed is the length of each section.

Let's start from the Z_l sections which are capacitor sections including g_1 , g_3 , g_5 and g_7 . By using the microstrip line calculation tool, when the line width is 5mm, $Z_l = 29.67\Omega$, wavelength $\lambda = 78.847\text{mm}$. According to 16-22, the first capacitor value is:

$$g_1 = C_1 = 0.4450$$

We get

$$\beta l_1 = C_1 Z_l / R_0$$

$$= 0.4450 * 29.67 / 50$$

$$= 0.264 \text{ rads} \quad (16-23)$$

Combining 16.8 and 16.23, the line length of l_1 and l_7 are:

$$l_1 = 0.264 / \beta$$

$$= 0.264 / (2\pi / \lambda)$$

$$= 0.264 / (2\pi / 78.847)$$

$$= 3.31 \text{ mm.}$$

By the same method, section 3 is:

$$\beta l_3 = 1.069 \text{ rads}$$

$$l_3 = l_5 = 13.4 \text{ mm.}$$

The Z_h (inductor) sections are also designed by the same method. By using the calculation tool, $Z_h = 101.73\Omega$ and wavelength $\lambda = 86.087\text{mm}$ when the line width is 0.5mm. According to 16-21:

$$g_2 = L_2 = 1.2470$$

We get

$$\begin{aligned}\beta \mathbf{l}_2 &= L_2 R_0 / Z_h \\ &= 1.2470 * 50 / 101.73 \\ &= 0.613 \text{ rads} \quad (16-24)\end{aligned}$$

Combining 16-8 and 16-24, the line length of \mathbf{l}_2 and \mathbf{l}_6 is:

$$\begin{aligned}\mathbf{l}_2 &= 0.613 / \beta \\ &= 86.087 * 0.613 / (2 * \pi) \\ &= 8.4 \text{ mm.}\end{aligned}$$

The section 4 is:

$$\beta \mathbf{l}_4 = 0.983 \text{ rads}$$

$$\mathbf{l}_4 = 13.5 \text{ mm}$$

We have to consider another issue in addition to the filter itself. The transmission line contains 50Ω impedance and is frequently put in front of the filter at both ends. Its width is 2.3mm defined by the PCB structure. In addition, SMA terminals are attached to the test module for external connection. The 2.3mm transmission line is too wide to be directly connected to the SMA terminals, therefore an extra 1.6mm line section is necessary for bridging them together.

Summarizing the above results, the entire filter is designed as in Figure 16-6.

- L1, L7: 5x3.3 mm
- L2, L6: 0.5x8.4 mm
- L3, L5: 5x13.4 mm
- L4: 0.5x13.5 mm
- Lo: 2.3x5 mm, for 50Ω transmission line

- L_p : 1.6x8 mm, for SMA connector pin.

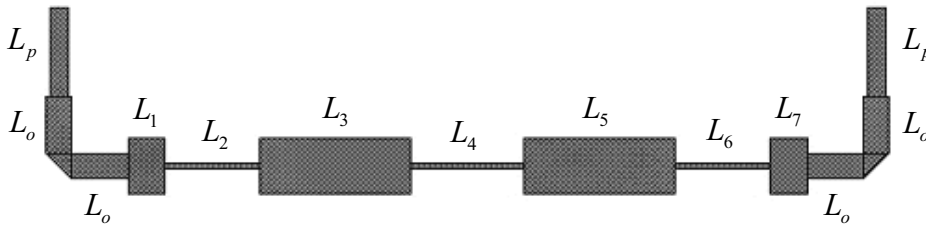

Figure 16-6

16-2-3. Fine tune and Modification

Just as mentioned in the previous section, the simulation tool is very useful and important for microwave circuit design. We can simulate our design to check if the result meets our design target. If not, we can do fine tuning and simulate again. By repeating this fine tune and simulate step, we can make the design as close as possible to the design target. In the above case, we find that the roll-off at $f_c=2\text{GHz}$ is 5dB more than we expected from the simulation result. It could be caused by the extra sections of the transmission line. Here we try to fine tune again by changing the l_4 from 13.5mm to 10mm where the roll-off becomes 2.5dB but the attenuation at 3GHz becomes less than 20dB, which is a trade-off. Both simulation results are drawn in Figure 16-7.

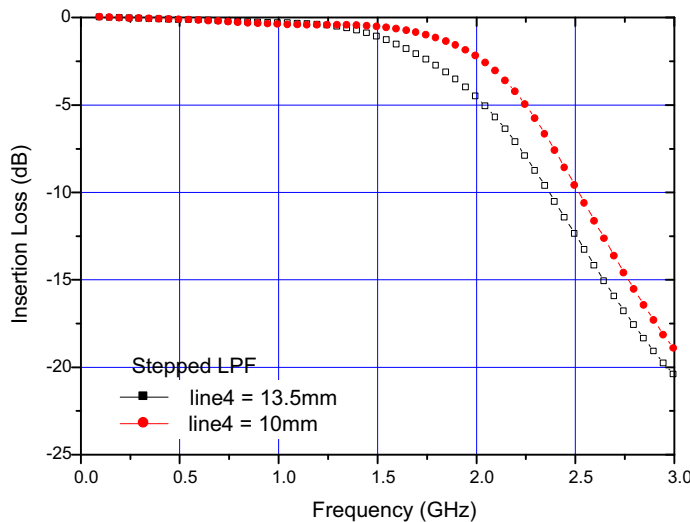

Figure 16-7

In the experiment, we will take the 10mm case for measurement.

16-3. Coupled line Band Pass Filter

Coupled line filter is a good choice if we want to design a band pass filter in microstrip form which requires bandwidth about less than 20%. Wider bandwidth filter generally require tightly coupled lines, which are hard to fabricate.

16-3-1. Design Example

We will design a coupled line filter with 0.5dB ripple, 2.4GHz center frequency, 15dB attenuation at 2GHz, and 10% bandwidth. The input and output impedance are both 50Ω. The PCB material is FR4 with dielectric constant of 4.2 and thickness of 1.2mm.

16-3-2. Solution

First, we need to decide the order of the filter.

$$\left| \frac{w}{wc} \right| - 1 = \left| \frac{1}{\Delta} \left(\frac{w}{w_0} - \frac{w_0}{w} \right) \right| = \frac{1}{0.1} \left(\frac{2}{2.4} - \frac{2.4}{2} \right) = |-3.67| - 1 = 2.67$$

Δ is the bandwidth ration and is equal to 0.1.

Referring to Figure 16-6, since $\frac{w}{wc} - 1 = 2.67$ and attenuation is 15dB at 2GHz,

the order (N) becomes 2. From Table 16-1, we find the normalized values of g1 to g3 as follows:

- g1=1.4029
- g2=0.7071
- g3=1.9841

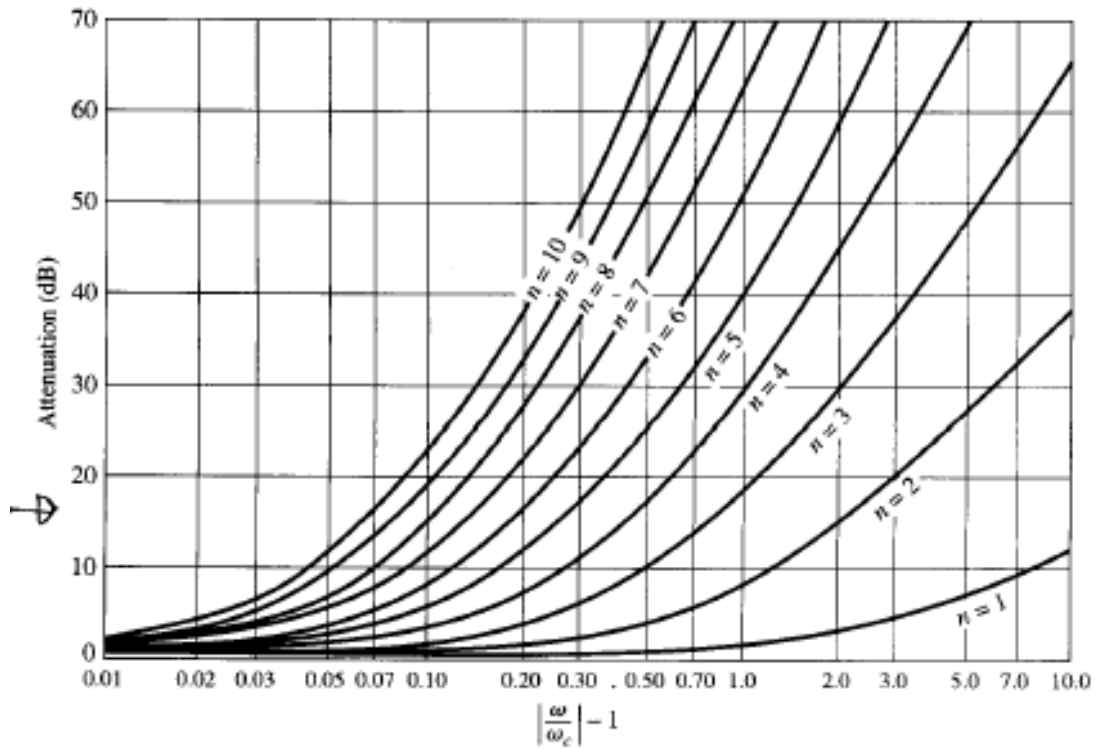

Figure 16-6

0.5dB Ripple

N	g1	g2	g3	g4	g5	g6	g7	g8	g9	g10	g11
1	0.6986	1.0000									
2	1.4029	0.7071	1.9841								
3	1.5963	1.0967	1.5963	1.0000							
4	1.6703	1.1926	2.3661	0.8419	1.9841						
5	1.7058	1.2296	2.5408	1.2296	1.7058	1.0000					
6	1.7254	1.2479	2.6064	1.3137	2.4758	0.8696	1.9841				
7	1.7372	1.2583	2.6381	1.3444	2.6381	1.2583	1.7372	1.0000			
8	1.7451	1.2647	2.6564	1.3590	2.6964	1.3389	2.5093	0.8796	1.9841		
9	1.7504	1.2690	2.6678	1.3673	2.7239	1.3673	2.6678	1.2690	1.7504	1.0000	
10	1.7543	1.2721	2.6754	1.3725	2.7392	1.3806	2.7231	1.3485	2.5239	0.8842	1.9841

Table 16-1

After that, we can use the follow equation to evaluate the even and odd mode of the characteristic impedance.

$$Z_0 J_1 = \sqrt{\frac{\pi\Delta}{2g_1}}$$

$$Z_0 J_N = \frac{\pi\Delta}{2\sqrt{g_{N-1}g_N}}$$

$$Z_0 J_{N+1} = \sqrt{\frac{\pi\Delta}{2g_{N+1}g_N}}$$

$$Z_{0e} = Z_0 \left[1 + JZ_0 + (JZ_0)^2 \right]$$

$$Z_{0o} = Z_0 \left[1 - JZ_0 + (JZ_0)^2 \right]$$

we can get:

$$Z_0 J_1 = 0.355$$

$$Z_0 J_2 = 0.158$$

$$Z_0 J_3 = 0.335$$

$$Z_{0e1} = 72.36$$

$$Z_{0o1} = 38.86$$

$$Z_{0e2} = 59.15$$

$$Z_{0o2} = 43.35$$

$$Z_{0e3} = 72.36$$

$$Z_{0o3} = 38.86$$

Due to the complexity of calculating the coupling coefficient, we can use CAD tools to find out the gap between coupling lines. The list below shows the results after the calculation:

- $l_1 = l_3 = 17.45\text{mm}$
- $w_1 = w_3 = 1.11.94\text{mm}$
- $s_1 = s_3 = 0.26\text{mm}$
- $l_2 = 17\text{mm}$
- $w_2 = 2.2\text{mm}$
- $s_2 = 1\text{mm}$

We still need to consider two issues: one is that the minimum practical distance is 0.5mm, and the other one that the impedance of pin connection lines is not 50Ω which affects the filter frequency response. Therefore, after fine tuning, the final result becomes as follows.

$$l_1 = l_3 = 16.9mm$$

$$w_1 = w_3 = 1.1mm$$

$$s_1 = s_3 = 0.5mm$$

$$l_2 = 17mm$$

$$w_2 = 2.2mm$$

$$s_2 = 0.9mm$$

Summarizing the above result, we get:

- L1, L3=1.1x16.9mm, gap=0.5mm
- L2=2.2x17mm, gap=0.9mm
- Lo=2.3x5mm, for 50Ω
- Lp=1.6x8mm, for pin connection

The entire filter is designed as Figure 16-7. The simulation results are shown in Figure 16-8.

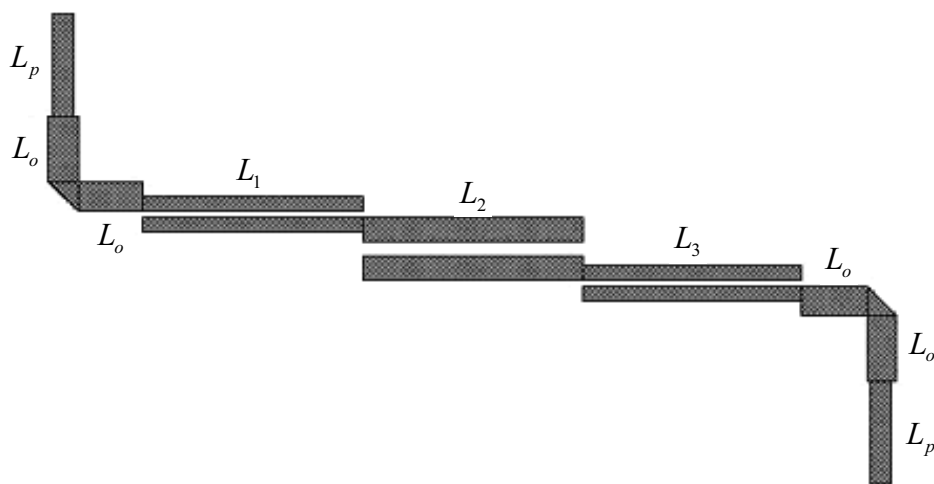

Figure 16-7

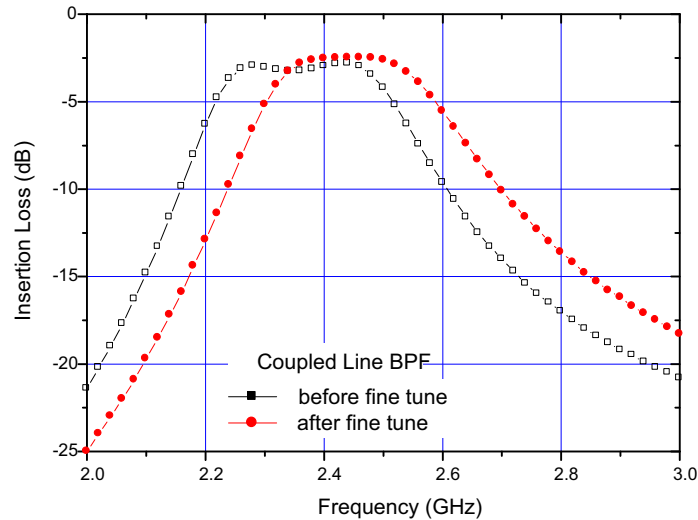

Figure 16-8

Fine-tuned values were used for actual measurements.

16-4. Optimized High Pass Filter

There are several ways to design a high pass filter in microstrip form. In this section, we will introduce an easy way to fabricate a high pass filter, which can also be considered as a wideband band pass filter.

16-4-1. Design Example

We will design a high pass filter with 0.1dB ripple and 1.5GHz cut off frequency. The input and output impedance are both 50Ω. The PCB material is FR4 with dielectric constant of 4.2 and thickness of 1.2 mm.

16-4-2. Solution

First, we assume that the pass band is from 1.5GHz to 4.7GHz.

$$4.7GHz = \left(\frac{\pi}{\vartheta_c} - 1 \right) \times f_c \rightarrow \vartheta_c = 35^\circ$$

Referring to Table 16-2, we choose $\vartheta_c = 35^\circ$ and $N = 4$, then y_1 , y_{12} , y_2 and y_{23} become as follows:

- $y_1=0.4467$
- $y_{12}=1.03622$

- $y_2=0.60527$
- $y_{23}=1.01536$

Figure 16-9 shows the structure of the filter.

n	Θ_c	Y_1	$Y_{1,2}$	Y_2	$Y_{2,3}$	Y_3	$Y_{3,4}$
		y_n	$y_{n-1,n}$	y_{n-1}	$y_{n-2, n-1}$	y_{n-2}	
2	25°	0.15436	1.13482				
	30°	0.22070	1.11597				
	35°	0.30755	1.08967				
3	25°	0.19690	1.12075	0.18176			
	30°	0.28620	1.09220	0.30726			
	35°	0.40104	1.05378	0.48294			
4	25°	0.22441	1.11113	0.23732	1.10361		
	30°	0.32300	1.07842	0.39443	1.06488		
	35°	0.44670	1.03622	0.60527	1.01536		
5	25°	0.24068	1.10540	0.27110	1.09317	0.29659	
	30°	0.34252	1.07119	0.43985	1.05095	0.48284	
	35°	0.46895	1.02790	0.66089	0.99884	0.72424	
6	25°	0.25038	1.10199	0.29073	1.08725	0.33031	1.08302
	30°	0.35346	1.06720	0.46383	1.04395	0.52615	1.03794
	35°	0.48096	1.02354	0.68833	0.99126	0.77546	0.98381

Table 16-2

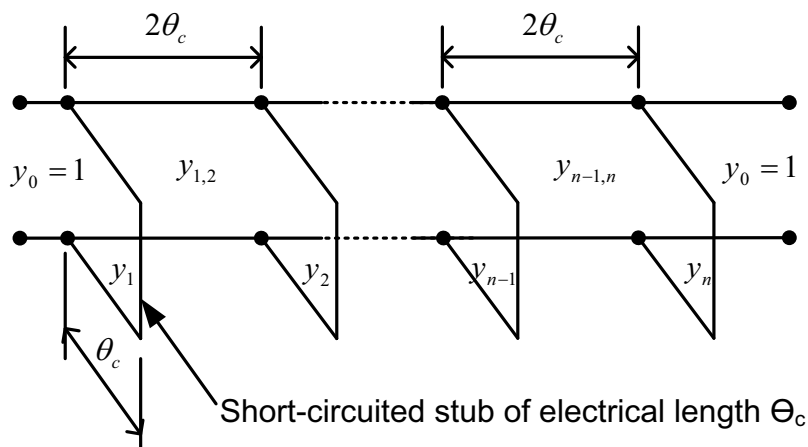

Figure 16-9

Now we can use the following equations to evaluate the line impedance.

$$Z_i = Z_0 / y_i, \vartheta = \vartheta_c$$

$$Z_{i,i+1} = Z_0 / y_{i,i+1}, \vartheta = 2\vartheta_c$$

We get:

$$Z_1 = 111.93$$

$$Z_{12} = 48.25$$

$$Z_2 = 82.16$$

$$Z_{23} = 49.24$$

And then we can use CAD tools to find out the real length and width of each section.

$$l_1 = 11.23mm$$

$$w_1 = 0.3762mm$$

$$l_{12} = 21.189mm$$

$$w_{12} = 2.43mm$$

$$l_2 = 11.02mm$$

$$w_2 = 0.867mm$$

$$l_{23} = 21.22mm$$

$$w_{23} = 2.35mm$$

We still need to consider two issues: one is that the minimum practical distance is 0.5mm, and the other one is the cross section of each line. Therefore, after fine tuning, the final result becomes as follows.

$$l_1 = 10.7mm$$

$$w_2 = 0.8mm$$

$$l_{12} = 21.2mm$$

$$w_{12} = 2.3mm$$

$$l_2 = 10.7mm$$

$$w_2 = 1mm$$

$$l_{23} = 21.2mm$$

$$w_{23} = 2.3mm$$

Summarizing the above results, we get

- $L_1 = 0.8 \times 10.7 \text{mm}$,
- $L_{12} = 2.3 \times 21.2 \text{mm}$, gap = 0.9mm
- $L_2 = 1 \times 10.7 \text{mm}$
- $L_{23} = 2.3 \times 21.2 \text{mm}$
- $L_o = 2.3 \times 5 \text{mm}$, for 50Ω
- $L_p = 1.6 \times 8 \text{mm}$, for pin connection

The end of L_1 and L_2 are grounded.

Figure 16-10 shows the design of the entire filter. The simulation results are shown in Figure 16-11.

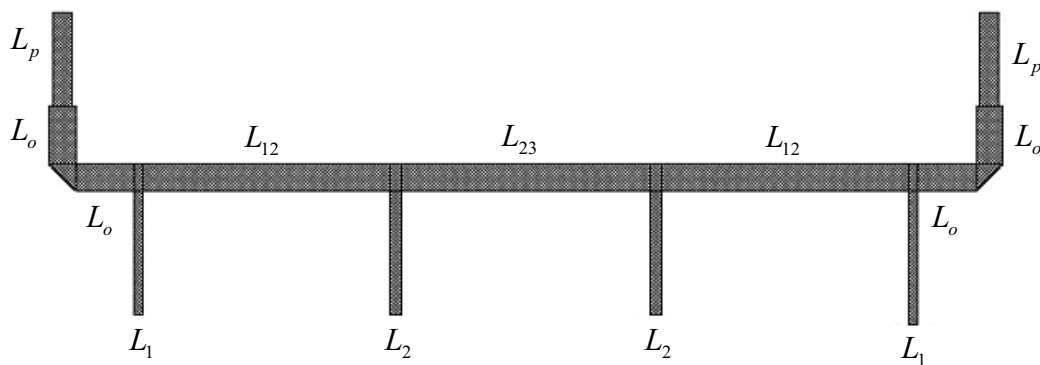

Figure 16-10

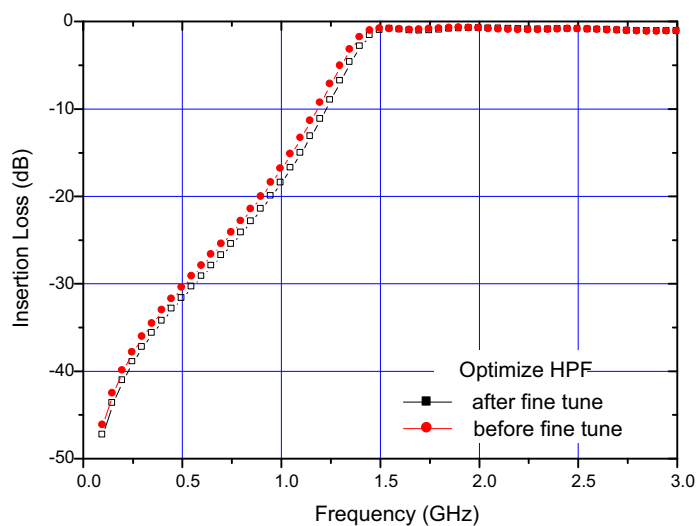

Figure 16-11

Fine-tuned values were used for actual measurements.

Questions

Question 1:

What is the possible factor, other than the design of the filter itself, that affects implement the transmission line filter?

Question 2:

Describe how to limit the tolerance caused by connectors.

Question 3:

Describe how to choose the right PCB for implementing microstrip line filters.

Experiments

Insertion Loss Measurement 1

Objective: Implement a microstrip low pass filter. Refer to Figure 16-12 or R-11 module in the GRF-3300.

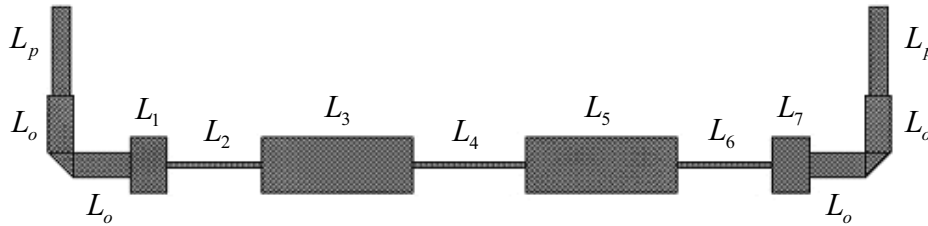

Figure 16-12 Microstrip line low pass filter

9. Prepare the following items.

- GRF-3300, R-11 (Microstrip Low-Pass Filter) module
- N-SMA Adaptor x 2
- RF cable, 75cm x 2
- Spectrum Analyzer (SA)

10. Configure the SA as follows.

- Frequency span: Full Span
- Resolution bandwidth (RBW): Auto

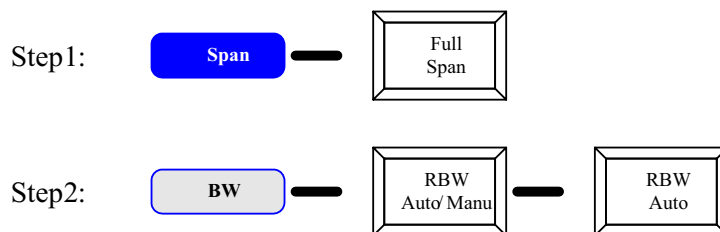

Figure 16-13 Spectrum analyzer configurations (GSP-830)

11. Activate and adjust the Tracking Generator (TG) as follows.

- TG Reference level: 10dBm
- TG level: 0dBm
- TG reference value: 0dBm

- TG output: on
- TG normalization: on

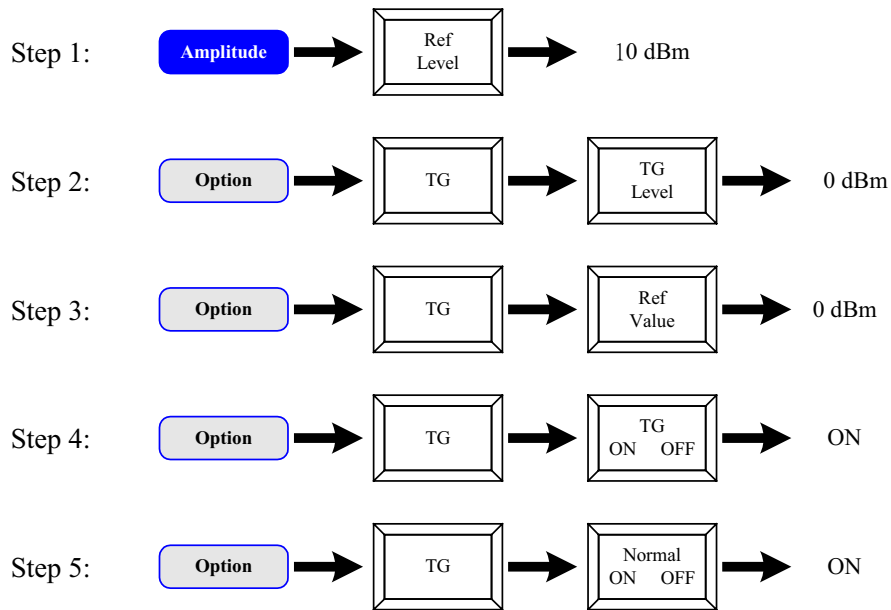

Figure 16-14 TG configurations

12. Connect the SA and R-11 as follows.

- TG output – R-11 input
- R-11 output – SA RF input

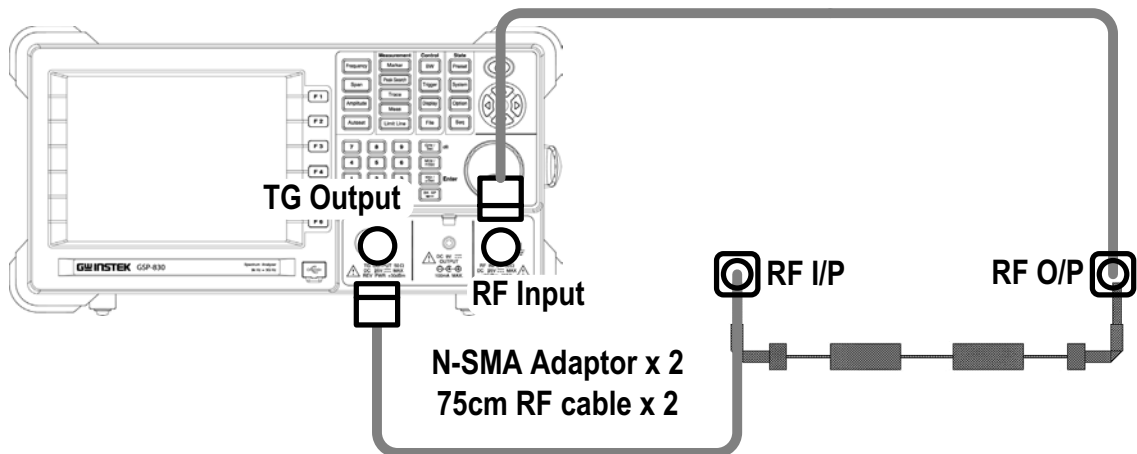

Figure 16-15 SA to R-11 connections

13. Turn on a marker in the SA, set the marker frequency to 3dB bandwidth of the filter, and record the amplifier gain into Chart 16-1.

Insertion Loss Measurement 2

Objective: Implement a microstrip line band pass filter. Refer to Figure 16-16 or T-1 module in the GRF-3300.

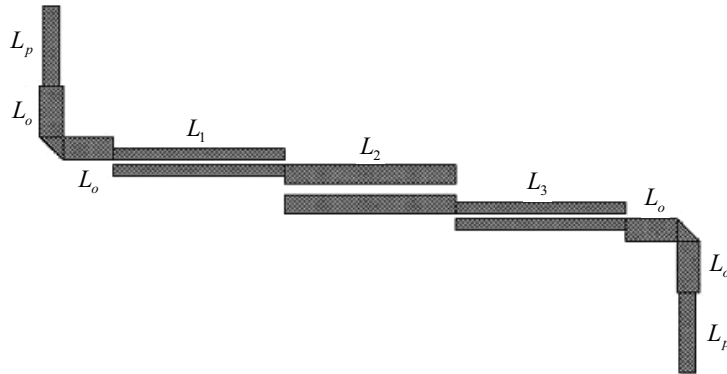

Figure 16-16 Microstrip line band pass filter

Follow the same steps as in the “Insertion Loss Measurement 1” section but change some items as follows.

- R-11 module → T-1 module
- Chart 16-1 → Chart 16-2

Insertion Loss Measurement 3

Objective: Implement a microstrip line high pass filter. Refer to Figure 16-17 or T-6 module in the GRF-3300.

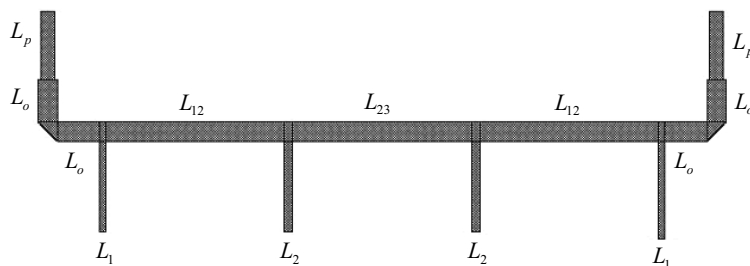

Figure 16-17 Microstrip line high pass filter

Follow the same steps as in the “Insertion Loss Measurement 1” section but change some items as follows.

- R-11 module → T-6 module
- Chart 16-1 → Chart 16-3

Experiment Results

Insertion Loss Measurement

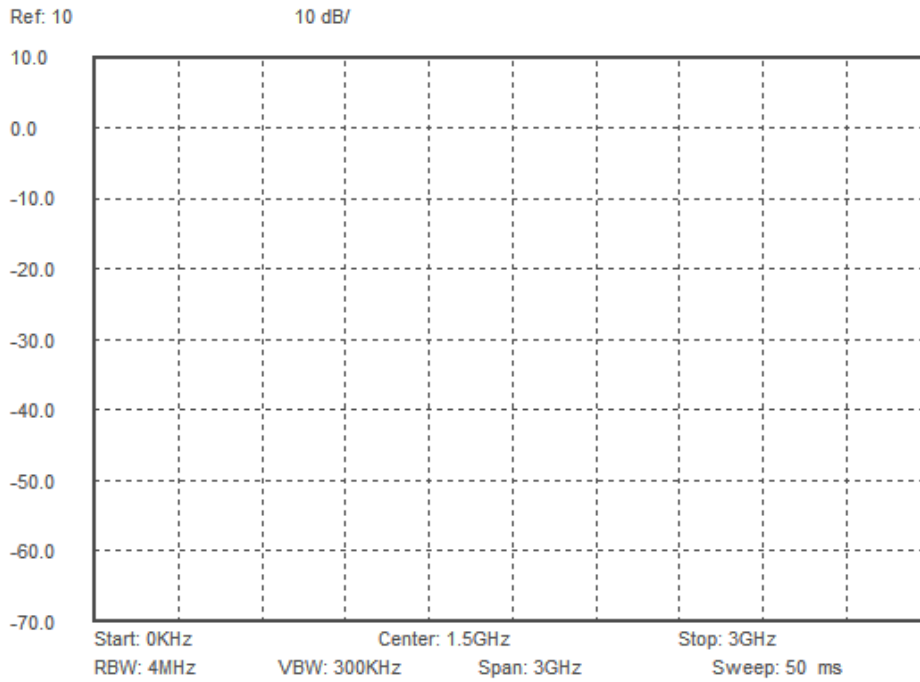

Chart 16-1 Measurement result of R-11 microstrip line low pass filter insertion loss

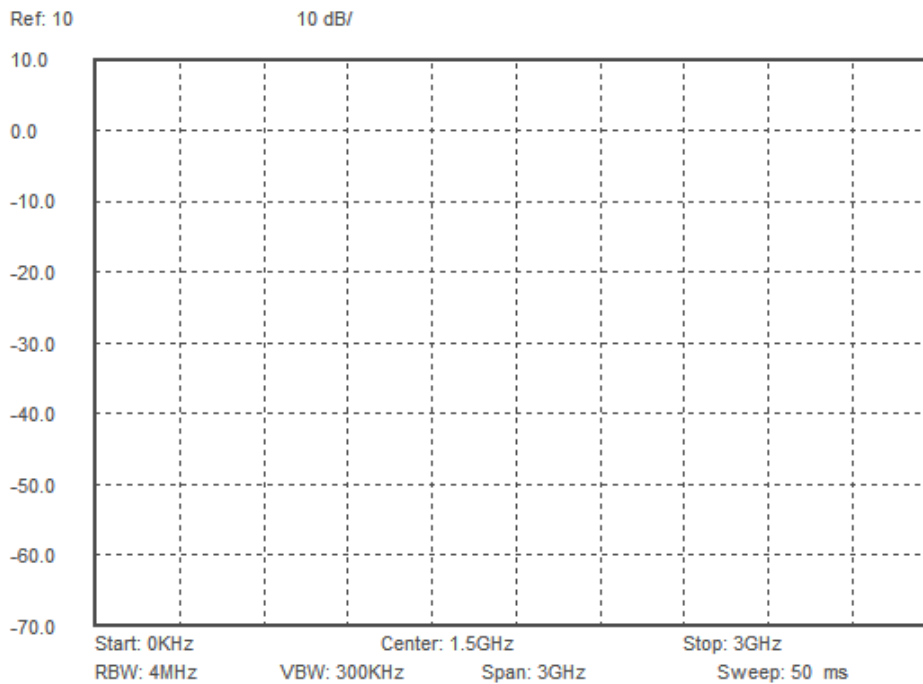

Chart 16-2 Measurement result of T-1 microstrip line band pass filter insertion loss

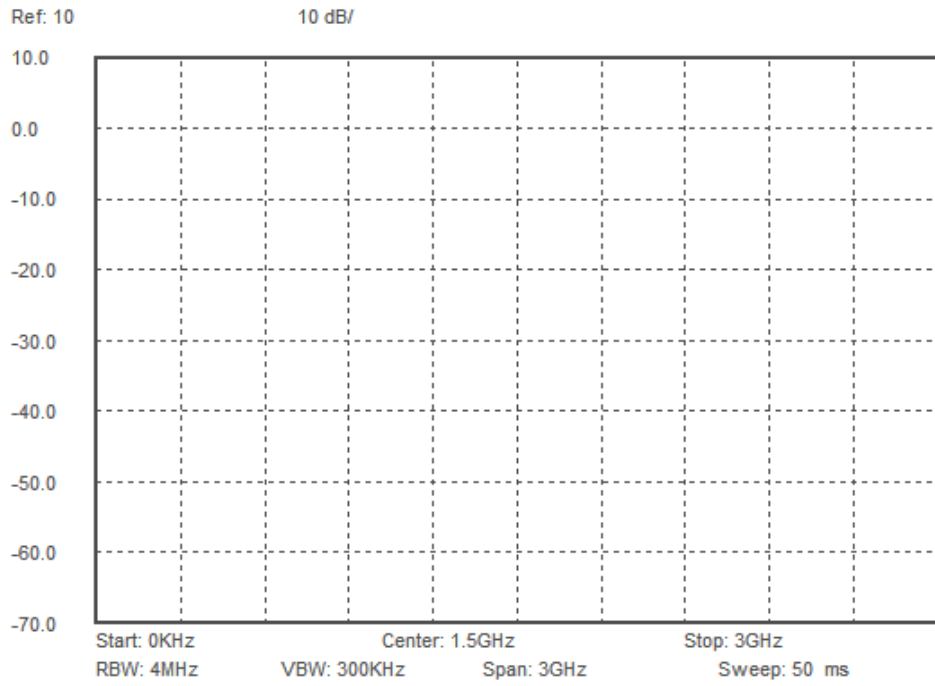

Chart 16-3 Measurement result of T-6 microstrip line high pass filter insertion loss