

Arbitrary Function Generator

AFG-2225

Quick Start Guide

GW INSTEK PART NO. 82AF-22250ME1



ISO-9001 CERTIFIED MANUFACTURER

GW INSTEK

This manual contains proprietary information, which is protected by copyright. All rights are reserved. No part of this manual may be photocopied, reproduced or translated to another language without prior written consent of Good Will Corporation.

The information in this manual was correct at the time of printing. However, Good Will continues to improve its products and therefore reserves the right to change the specifications, equipment, and maintenance procedures at any time without notice.

Good Will Instrument Co., Ltd.
No. 7-1, Jhongsing Rd., Tucheng Dist., New Taipei City 236, Taiwan.

Table of Contents

SAFETY INSTRUCTIONS	2
GETTING STARTED	7
Main Features	7
Panel Overview.....	9
Setting Up the function Generator.....	15
QUICK REFERENCE	17
How to use the Digital Inputs	19
How to use the Help Menu	21
Selecting a Waveform	23
Modulation.....	25
Sweep.....	31
Burst	33
ARB.....	35
Utility Menu	38
Frequency Counter.....	39
coupling	40
Menu Tree	42
Default Settings	50
AFG-2225 Specifications.....	52
EC Declaration of Conformity	57

S SAFETY INSTRUCTIONS

This chapter contains important safety instructions that should be followed when operating and storing the function generator. Read the following before any operation to ensure your safety and to keep the function generator in the best condition.

Safety Symbols

These safety symbols may appear in this manual or on the instrument.



WARNING

Warning: Identifies conditions or practices that could result in injury or loss of life.



CAUTION

Caution: Identifies conditions or practices that could result in damage to the function generator or to other objects or property.



DANGER High Voltage



Attention: Refer to the Manual



Protective Conductor Terminal



Earth (Ground) Terminal



DANGER Hot Surface



Double Insulated



Do not dispose electronic equipment as unsorted municipal waste. Please use a separate collection facility or contact the supplier from which this instrument was purchased.

Safety Guidelines

General
Guideline





CAUTION

- Do not place heavy objects on the instrument.
- Do not place flammable objects on the instrument.
- Avoid severe impact or rough handling that may damage the function generator.
- Avoid discharges of static electricity on or near the function generator.
- Use only mating connectors, not bare wires, for the terminals.
- The instrument should only be disassembled by a qualified technician.

(Measurement categories) EN 61010-1:2010 specifies the measurement categories and their requirements as follows. The AFG-2225 falls under category II.

- Measurement category IV is for measurement performed at the source of a low-voltage installation.
 - Measurement category III is for measurement performed in a building installation.
 - Measurement category II is for measurement performed on circuits directly connected to a low voltage installation.
 - Measurement category I is for measurements performed on circuits not directly connected to Mains.
-

- Power Supply
- AC Input voltage: 100 ~ 240V AC, 50 ~ 60Hz.
-  **WARNING**
- Connect the protective grounding conductor of the AC power cord to an earth ground to prevent electric shock.

- Fuse
- Fuse type: F1A/250V.
-  **WARNING**
- Only qualified technicians should replace the fuse.
 - To ensure fire protection, replace the fuse only with the specified type and rating.
 - Disconnect the power cord and all test leads before replacing the fuse.
 - Make sure the cause of fuse blowout is fixed before replacing the fuse.

- Cleaning the function generator
- Disconnect the power cord before cleaning the function generator.
 - Use a soft cloth dampened in a solution of mild detergent and water. Do not spray any liquid into the function generator.
 - Do not use chemicals containing harsh products such as benzene, toluene, xylene, and acetone.

- Operation Environment
- Location: Indoor, no direct sunlight, dust free, almost non-conductive pollution (Note below) and avoid strong magnetic fields.
 - Relative Humidity: < 80%
 - Altitude: < 2000m
 - Temperature: 0°C to 40°C

(Pollution Degree) EN 61010-1:2010 specifies pollution degrees and their requirements as follows. The function generator falls under degree 2.

Pollution refers to “addition of foreign matter, solid, liquid, or gaseous (ionized gases), that may produce a reduction of dielectric strength or surface resistivity”.

- Pollution degree 1: No pollution or only dry, non-conductive pollution occurs. The pollution has no influence.
- Pollution degree 2: Normally only non-conductive pollution occurs. Occasionally, however, a temporary conductivity caused by condensation must be expected.
- Pollution degree 3: Conductive pollution occurs, or dry, non-conductive pollution occurs which becomes conductive due to condensation which is expected. In such conditions, equipment is normally protected against exposure to direct sunlight, precipitation, and full wind pressure, but neither temperature nor humidity is controlled.

Storage environment

- Location: Indoor
- Relative Humidity: < 70%
- Temperature: -10°C to 70°C

Disposal



Do not dispose this instrument as unsorted municipal waste. Please use a separate collection facility or contact the supplier from which this instrument was purchased. Please make sure discarded electrical waste is properly recycled to reduce environmental impact.

Power cord for the United Kingdom

When using the function generator in the United Kingdom, make sure the power cord meets the following safety instructions.

NOTE: This lead/appliance must only be wired by competent persons



WARNING: THIS APPLIANCE MUST BE EARTHED

IMPORTANT: The wires in this lead are coloured in accordance with the following code:

Green/ Yellow:	Earth
Blue:	Neutral
Brown:	Live (Phase)



As the colours of the wires in main leads may not correspond with the coloured marking identified in your plug/appliance, proceed as follows:

The wire which is coloured Green & Yellow must be connected to the Earth terminal marked with either the letter E, the earth symbol (⊕) or coloured Green/Green & Yellow.

The wire which is coloured Blue must be connected to the terminal which is marked with the letter N or coloured Blue or Black.

The wire which is coloured Brown must be connected to the terminal marked with the letter L or P or coloured Brown or Red.

If in doubt, consult the instructions provided with the equipment or contact the supplier.

This cable/appliance should be protected by a suitably rated and approved HBC mains fuse: refer to the rating information on the equipment and/or user instructions for details. As a guide, a cable of 0.75mm² should be protected by a 3A or 5A fuse. Larger conductors would normally require 13A types, depending on the connection method used.

Any exposed wiring from a cable, plug or connection that is engaged in a live socket is extremely hazardous. If a cable or plug is deemed hazardous, turn off the mains power and remove the cable, any fuses and fuse assemblies. All hazardous wiring must be immediately destroyed and replaced in accordance to the above standard.

G E T T I N G S T A R T E D

The Getting started chapter introduces the function generator's main features, appearance, set up procedure and power-up.

Main Features

Model	Bandwidth
AFG-2225	25MHz
Performance	<ul style="list-style-type: none"> • DDS function generator series • 1μHz high frequency resolution maintained at full range • 20ppm frequency stability • Arbitrary waveform capability • 120 MSa/S sample rate • 60 MSa/S repetition rate • 4k point waveform length • 10 groups of 4k waveform memories • True waveform output to display • User defined output section • DWR (Direction Waveform Reconstruction) • Waveform editing via PC.
Features	<ul style="list-style-type: none"> • Sine, Square, Ramp, Pulse, Noise, standard waveforms • Internal and external LIN/LOG sweep with marker output • Int/Ext AM, FM, PM, FSK, SUM modulation

- Burst function with internal and external triggers without marker output
 - Store/recall 10 groups of setting memories
 - Output overload protection
-

Interface

- USB interface as standard
- 3.5" color TFT LCD (320× 240) graphical user interface.
- AWES (Arbitrary Waveform Editing Software) PC software

Panel Over view

Front Panel

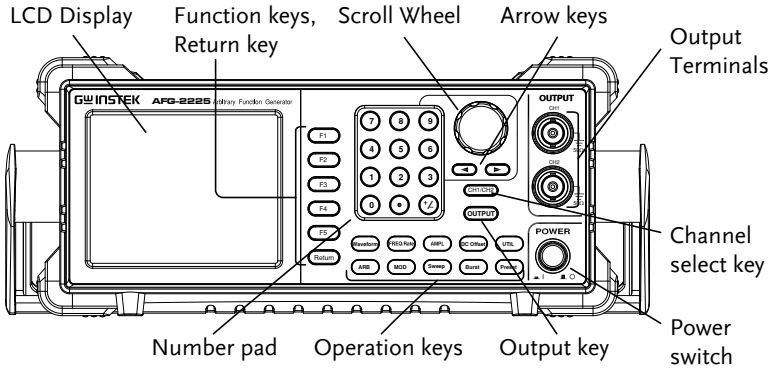

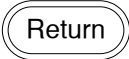

LCD Display TFT color display, 320 x 240 resolution.

Function Keys
F1~F5  Activates functions which appear on the right-hand side of the LCD display.

Return Key  Goes back to the previous menu level.

Operation Keys  The waveform key is used to select a type of waveform.

 The FREQ/Rate key is used to set the frequency or sample rate.

 AMPL sets the waveform amplitude.

 Sets the DC offset.



The UTIL key is used to access the save and recall options, update and view the firmware version, access the calibration options, dual channel settings and frequency meter.



ARB is used to set the arbitrary waveform parameters.



The MOD, Sweep and Burst keys are used to set the modulation, sweep and burst settings and parameters.



Preset Key



The preset key is used to recall a preset state.

Output Key



The Output key is used to turn on or off the waveform output.

Channel Select Key

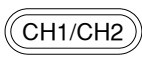

The channel select key is used to switch between the two output channels.

Output ports

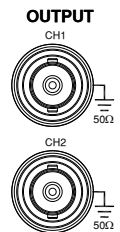

CH1: Channel 1 output port
CH2: Channel 2 output port

Power Button

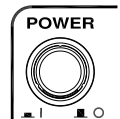

Turns the power on or off.

Arrow Keys



Used to select digits when editing parameters.

Scroll Wheel

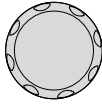

The scroll wheel is used to edit values and parameters.

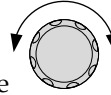

Decrease

Increase

Keypad

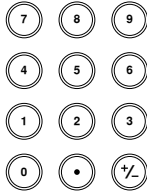

The digital keypad is used to enter values and parameters. The keypad is often used in conjunction with the selection keys and variable knob.

Rear Panel

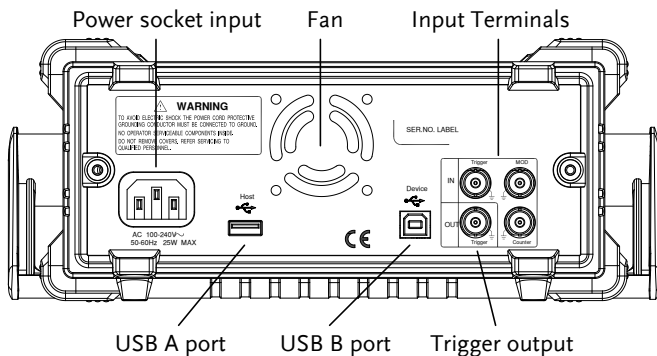

Trigger Input

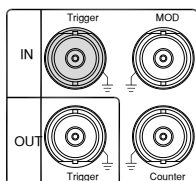

External trigger input. Used to receive external trigger signals.

Trigger Output

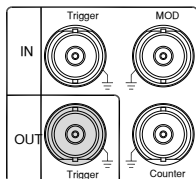

Marker output signal. Used for Sweep, Burst and ARB mode only.

Fan

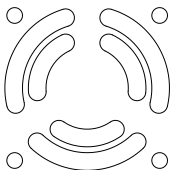

Fan.

Power Input Socket

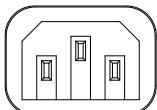

AC 100-240V~
50-60Hz 25W MAX

Power input: 100~240V AC
50~60Hz.

USB Host



USB A Host port.

USB B Port

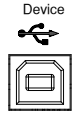

The type-B USB connector is used to connect the function generator to a PC for remote control.

Counter Input

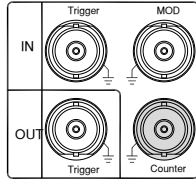

Frequency counter input.

MOD Input

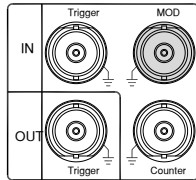

Modulation input terminal.

Display



Parameter Windows The Parameter display and edit window.

Status Tabs Displays the current channel and setting status.

Waveform Display Used to display the waveform

Soft Menu Keys The function keys (F1~F5) beside the Soft Menu keys correspond to the soft keys.

Setting Up the function Generator

Background This section describes how adjust the handle and power up the function generator.

Adjusting the Handle

Pull out the handle sideways and rotate it.

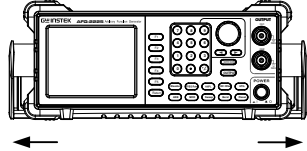

Place the AFG-2225 horizontally,

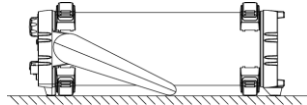

Or tilt the stand.

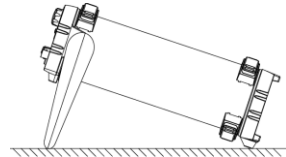

Place the handle vertically to hand carry.

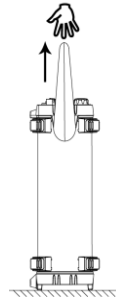

Power Up

1. Connect the power cord to the socket on the rear panel.

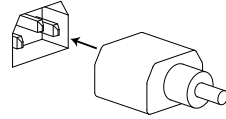

2. Turn on the power switch on the front panel.

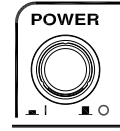

3. When the power switch is turned on the screen displays the loading screen.



The function generator is now ready to be used.

QUICK REFERENCE

This chapter describes the operation shortcuts, built-in help and factory default settings. This chapter is to be used as a quick reference, for detailed explanations on parameters, settings and limitations, please see the user manual.

How to use the Digital Inputs	19
How to use the Help Menu	21
Selecting a Waveform	23
Square Wave.....	23
Ramp Wave	23
Sine Wave.....	24
Modulation.....	25
AM	25
FM.....	26
FSK Modulation.....	27
PM Modulation	28
SUM Modulation.....	29
Sweep.....	30
Burst	33
ARB	35
ARB-Add Built-In Waveform.....	35
ARB- Add Point.....	35
ARB- Add Line	36
ARB- Output Section	36
Utility Menu	38
Save	38
Recall	38
Frequency Counter	39
Frequency Coupling	40
Amplitude Coupling	40
Tracking.....	41
Menu Tree	42
Waveform	42

ARB-Display.....	42
ARB-Edit	44
ARB- Built In.....	44
ARB-Save	44
ARB-Load.....	45
ARB-Output.....	45
MOD	46
SWEEP.....	46
SWEEP- More.....	47
Burst- N Cycle	48
Burst – Gate	48
UTIL.....	48
CH1/CH2	49
Default Settings.....	50
AFG-2225 Specifications.....	52
EC Declaration of Conformity	57

How to use the Digital Inputs

Background

The AFG-2225 has three main types of digital inputs: the number pad, arrow keys and scroll wheel. The following instructions will show you how to use the digital inputs to edit parameters.

1. To select a menu item, press the corresponding function keys below (F1~F5). For example the function key F1 corresponds to the Soft key "Sine".



2. To edit a digital value, use the selector key to move the cursor to the digit that needs to be edited.



CH1 ON 50Ω	CH2 ON 50Ω
FREQ: 1.000000kHz	FREQ: 1.000000kHz
AMPL: 3.00Vpp	AMPL: 3.00Vpp
Offset: 0.00Vdc	Offset: 0.00Vdc
Phase: 0.0°	Phase: 0.0°

3. Use the scroll wheel to edit the parameter. Clockwise increases the value, counter clockwise decreases the value.

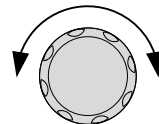

4. Alternatively, the number pad can be used to set the value of a highlighted parameter.

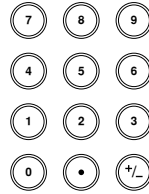

How to use the Help Menu

Background Every key and function has a detailed description in the help menu.

1. Press UTIL.



2. Press System (F3).



3. Press Help (F2).

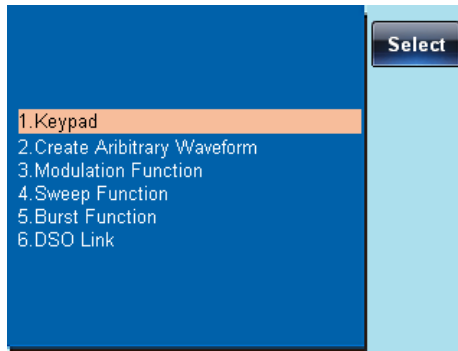

4. Use the scroll wheel to navigate to a help item. Press Select to choose the item.

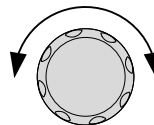

Keypad	Provides help on any front panel key that is pressed.
Create Arbitrary Waveform	Provides help on creating arbitrary waveforms.
Modulation Function	Explains how to create Modulated waveforms.
Sweep Function	Provides help on the Sweep function.

- Burst Function Provides help on the Burst function.
- DSO Link Provides help on DSO link.

5. For example, select item 4 to see help on the sweep function.

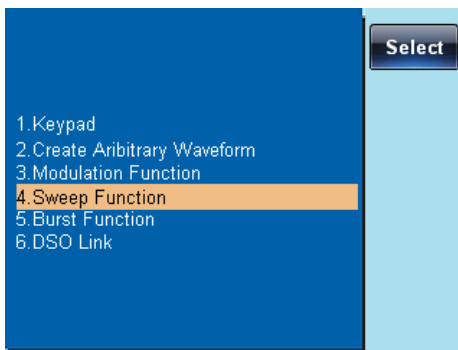

6. Use the scroll wheel to navigate the help information.

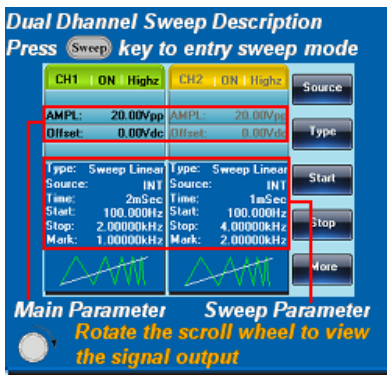

7. Press Return to return to the previous menu. 

Selecting a Waveform

Square Wave

Example: Square wave, 3Vpp, 75% duty cycle, 1kHz.

Output:

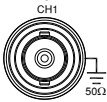

1. Press Waveform and select Square (F2).



2. Press Duty (F1), 7 + 5 + % (F2).



Input: N/A

3. Press Freq/Rate, 1 + kHz (F4).



4. Press AMPL followed by, 3 + VPP (F5).



5. Press the Output key.



Ramp Wave

Example: Ramp Wave, 5Vpp, 10kHz, 50% Symmetry

Output:

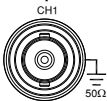

1. Press the Waveform key, and select Ramp (F4).





2. Press SYM(F1), 5 + 0 + % (F2).



Input: N/A

3. Press the Freq/Rate key then 1 + 0 + kHz (F4).



4. Press the AMPL key  5  then 5 +VPP (F5).
5. Press the Output key. 





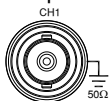

Sine Wave

Example: Sine Wave, 10Vpp,100kHz

Output:



Input: N/A

1. Press the Waveform key and select Sine   (F1).
2. Press the Freq/Rate key, followed by 1 + 0 +0 + kHz (F4).  1 0 0 
3. Press the AMPL key, followed by 1 + 0 +VPP (F5).  1 0 
4. Press the output key. 

Modulation

AM

Example: AM modulation. 100Hz modulating square wave. 1kHz Sine wave carrier. 80% modulation depth.

Output:

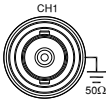

1. Press the MOD key and select AM (F1).



2. Press Waveform and select Sine (F1).



Input: N/A

3. Press the Freq/Rate key, followed by 1 + kHz (F4).



4. Press the MOD key, select AM (F1), Shape (F4), Square (F2).



5. Press the MOD key, select AM (F1), AM Freq (F3).

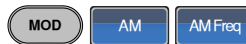

6. Press 1 + 0 + 0 + Hz (F2).



7. Press the MOD key, select AM (F1), Depth (F2).



8. Press 8 + 0 + % (F1).



9. Press MOD, AM (F1), Source (F1), INT (F1).



10. Press the output key. 

FM

Example: FM modulation. 100Hz modulating square wave. 1kHz Sine wave carrier. 100 Hz frequency deviation. Internal Source.

Output:

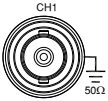

1. Press the MOD key and select FM (F2).



2. Press Waveform and select Sine (F1).



Input: N/A

3. Press the Freq/Rate key, followed by 1 + kHz (F4).



4. Press the MOD key, select FM (F2), Shape (F4), Square (F2).



5. Press the MOD key, select FM (F2), FM Freq (F3).



6. Press 1 + 0 + 0 + Hz (F2).





7. Press the MOD key, select FM (F2), Freq Dev (F2).



8. Press 1 + 0 + 0 + Hz (F3).



9. Press MOD, FM (F2), Source (F1), INT (F1).
- 

10. Press the Output key.
- 

FSK Modulation

Example: FSK modulation. 100Hz Hop frequency. 1kHz Carrier wave. Sine wave. 10 Hz Rate. Internal Source.

Output:

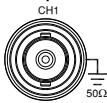

1. Press the MOD key and select FSK (F3).
- 

2. Press Waveform and select Sine (F1).
- 

Input: N/A



3. Press the Freq/Rate key, followed by 1 + kHz (F4).
- 

4. Press the MOD key, select FSK (F3), FSK Rate (F3).
- 

5. Press 1 + 0 + Hz (F2).
- 

6. Press the MOD key, select FSK (F3), Hop Freq (F2).
- 

7. Press 1 + 0 + 0 + Hz (F3).
- 



8. Press MOD, FSK (F3), Source (F1), INT (F1).
 
9. Press the output key.
 

PM Modulation



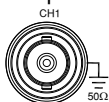



Example: PM modulation. 800Hz sinusoidal carrier wave. 15 kHz modulating sine wave. 50° phase deviation. Internal Source.



Output:



1. Press Waveform and select Sine (F1).
 
2. Press the MOD key and select PM (F4).
 

Input: N/A

3. Press the FREQ/Rate key, followed by 8 + 0 + 0 + Hz (F3).
 
4. Press the MOD key, select PM (F4), Shape (F4), Sine (F1).
 
5. Press MOD, then PM (F4), PM Freq (F3).
 
6. Press 1 + 5 + kHz (F3).
 
7. Press MOD, PM (F4), PM Dev (F2).
 
8. Press 5 + 0 + Degree (F1).
 



9. Press MOD, PM (F4), Source (F1), INT (F1).
 
10. Press the Output key.
 

SUM Modulation



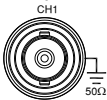

Example: SUM modulation. 100Hz modulating square wave, 1kHz sinusoidal carrier wave, 50% SUM amplitude, internal source.

Output:

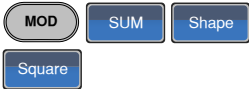
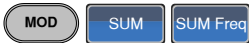

1. Press the MOD key, then SUM (F5).
 
2. Press Waveform, and select Sine (F1).
 

Input: N/A

3. Press Freq/Rate followed by 1 + kHz (F4).
 
4. Press the MOD key, SUM (F5), Shape (F4), Square (F2).
 
5. Press the MOD key and select SUM (F5), SUM Freq (F3).
 
6. Press 1 + 0 + 0 + Hz (F2).
 
7. Press the MOD key and select SUM (F5), SUM Ampl (F2).
 
8. Press 5 + 0 + % (F1).
 

9. Press MOD, SUM
(F5), Source (F1), INT
(F1).

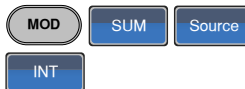

10. Press the Output key.



Sweep

Example: Frequency Sweep. Start Frequency 10mHz, Stop frequency 1MHz. Log sweep, 1 second sweep, Marker Frequency 550 Hz, Manual Trigger.

Output:

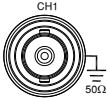

1. Press Sweep, Start (F3).



2. Press 1 + 0 + mHz (F2).



3. Press Sweep, Stop (F4).



Input: N/A

4. Press 1 + MHz (F5).



5. Press Sweep, Type (F2), Log (F2).

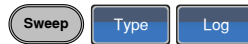

6. Press Sweep, More (F5), SWP Time (F1).



7. Press 1 + SEC (F2).



8. Press Sweep, More (F5), Marker (F4), ON/OFF (F2), Freq (F1).



9. Press 5 + 5 + 0 + Hz (F3).



10. Press the Output key.



11. Press Sweep, Source (F1), Manual (F3), Trigger (F1).

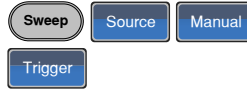

Burst

Example: Burst Mode, N-Cycle (Internally triggered), 1kHz burst frequency, Burst count = 5, 10 ms Burst period, 0° burst phase, Internal trigger, 10 us delay, rising edge trigger out

Output:

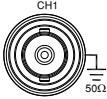

1. Press **FREQ/Rate 1** kHz (F4).



2. Press **Burst, N Cycle** (F1), **Cycles** (F1).



Input: N/A

3. Press **5 + Cyc** (F2).



4. Press **Burst, N Cycle** (F1), **Period** (F4).

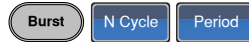

5. Press **1 + 0 + msec** (F2).



6. Press **Burst, N Cycle** (F1), **Phase** (F3).

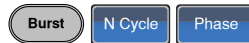

7. Press **0 + Degree** (F2).



8. Press **Burst, N Cycle** (F1), **TRIG set** (F5), **INT** (F1).



9. Press **Burst, N Cycle** (F1), **TRIG set** (F5), **Delay** (F4).

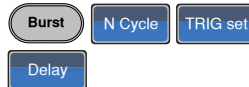

10. Press **1 + 0 + uSEC** (F2).



11. Press Burst, N Cycle (F1), TRIG set (F5), TRIG out (F5), ON/OFF (F3), Rise (F1).



12. Press the Output key.



ARB

ARB–Add Built-In Waveform

Example: ARB Mode, Exponential Rise. Start 0, Length 100, Scale 327.

Output:

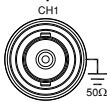

1. Press ARB, Built in (F3), Wave (F4), Math(F2), use the scroll wheel to select Exporise and then press Select(F5).



2. Press Start (F1), 0 + Enter (F2), Return.

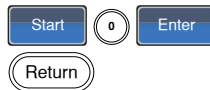

3. Press Length (F2), 100, Enter (F2), Return.

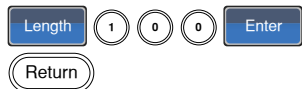

4. Press Scale (F3), 327, Enter (F2), Return, Done (F5).



ARB- Add Point

Example: ARB Mode, Add point, Address 40, data 300.

Output:

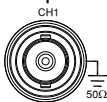

1. Press ARB, Edit (F2), Point (F1), Address (F1)

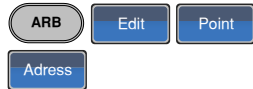

2. Press 4 + 0 + Enter (F2), Return

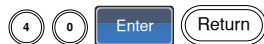

3. Press Data (F2),
3+0+0, Enter (F2).



ARB- Add Line

Example: ARB Mode, Add line, Address:Data (10:30, 50:100)

Output:

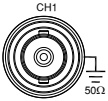

1. Press ARB, Edit (F2),
Line (F2), Start ADD
(F1).



2. Press 1 + 0 + Enter
(F2), Return.



3. Press Start Data (F2),
3 + 0, Enter (F2),
Return.

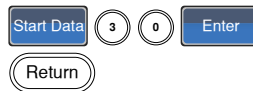

4. Press Stop ADD (F3),
5 + 0, Enter (F2),
Return.

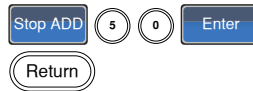

5. Press Stop Data (F4),
1 + 0 + 0, Enter (F2),
Return, Done (F5).

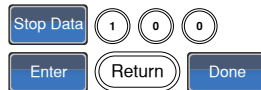

ARB– Output Section

Example: ARB Mode, Output ARB Waveform, Start 0, Length 1000.

Output:

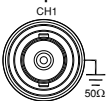





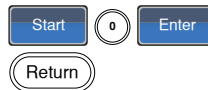

1. Press ARB, Output
(F4).



2. Press Start (F1), 0 +
Enter (F2), Return.





3. Press Length (F2), 1 +    
0 + 0, Enter (F2),
Return.  

Utility Menu



Save

Example: Save to Memory file #5.

1. Press UTIL, Memory (F1), Store (F1).

2. Choose a setting using the scroll wheel and press Done (F5).

Recall

Example: Recall Memory file #5.

1. Press UTIL, Memory (F1), Recall (F2).

2. Choose a setting using the scroll wheel and press Done (F5).

Frequency Counter

Frequency Counter

Example: Turn on the frequency counter. Gate time: 1 second.

Output: N/A

1. Press UTIL, Counter (F5).



Input:

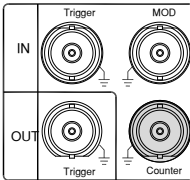

2. Press Gate Time (F1), and press 1 Sec (F3) to choose a gate time of 1 second.







3. Connect the signal of interest to the Frequency counter input on the rear panel.

coupling





Frequency Coupling

Example: Frequency Coupling

1. Press UTIL, Dual Chan (F4) to enter the coupling function.  
2. Press Freq Cpl (F1) to select the frequency coupling function. 
3. Press Offset (F2). The offset is the frequency difference between CH1 and CH2. Use the number keys or scroll wheel to enter the offset. 

Amplitude Coupling





Example: Amplitude Coupling

1. Press UTIL, Dual Chan (F4) to enter the coupling function.  
2. Press Ampl Cpl (F2), ON (F1) to select the amplitude coupling function.  

3. Couples the amplitude and offset between both channels. Any changes in amplitude in the current channel are reflected in the other channel.

Tracking

Example: Tracking

1. Press UTIL, Dual Chan (F4) to enter the coupling function.  
2. Press Tracking (F3), ON (F2) to turn on the tracking function.  
3. When tracking is turned on, parameters such as amplitude and frequency from the current channel are mirrored on the other channel.

Menu Tree

Conventions Use the menu trees as a handy reference for the function generator functions and properties. The AFG-2225 menu system is arranged in a hierarchical tree. Each hierarchical level can be navigated with the operation or soft menu keys. Pressing the Return key will return you to the previous menu level.

Waveform

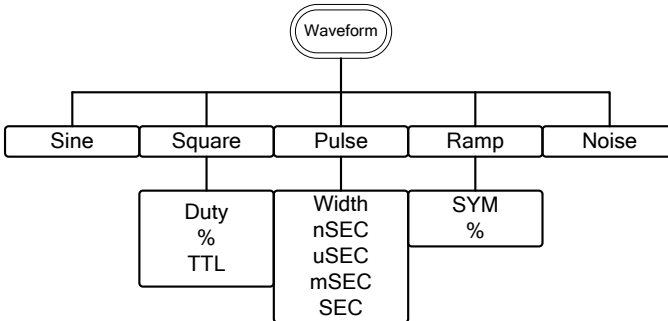

ARB-Display

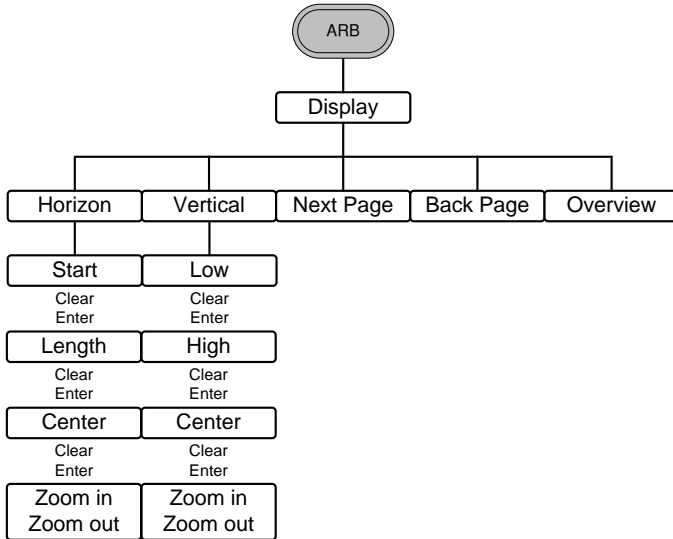

ARB-Edit

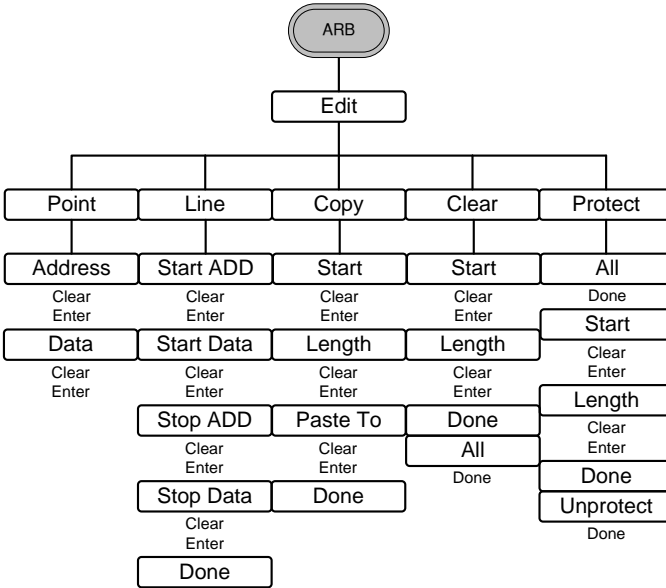

ARB- Built In

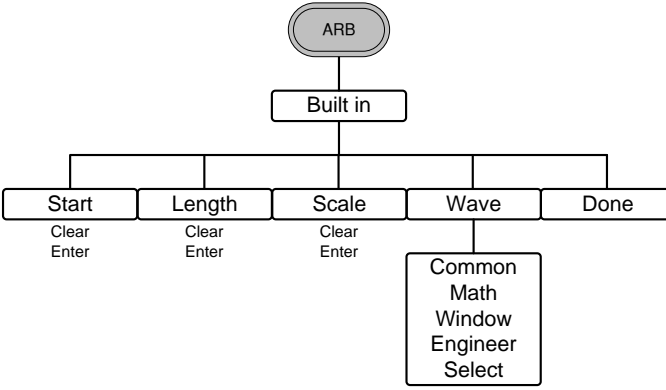

ARB-Save

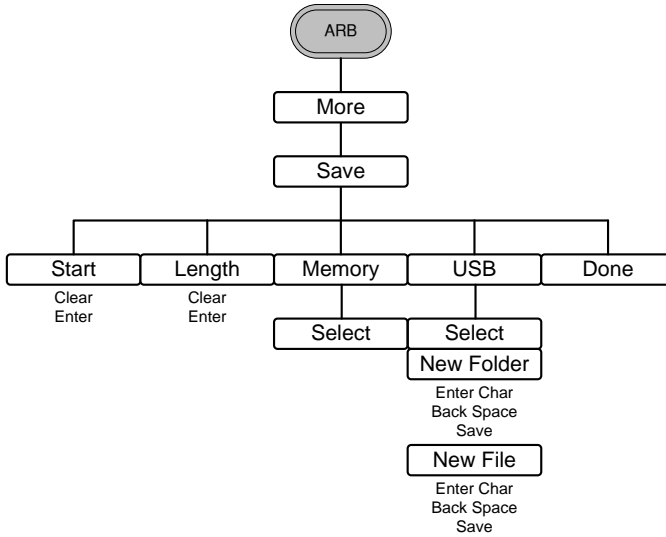

ARB-Load

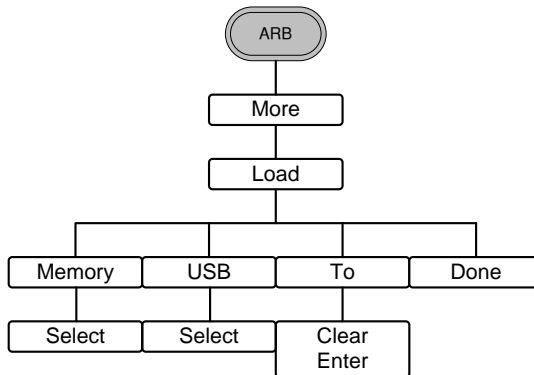

ARB-Output

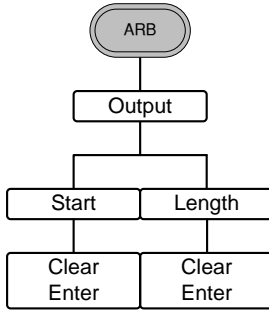

MOD

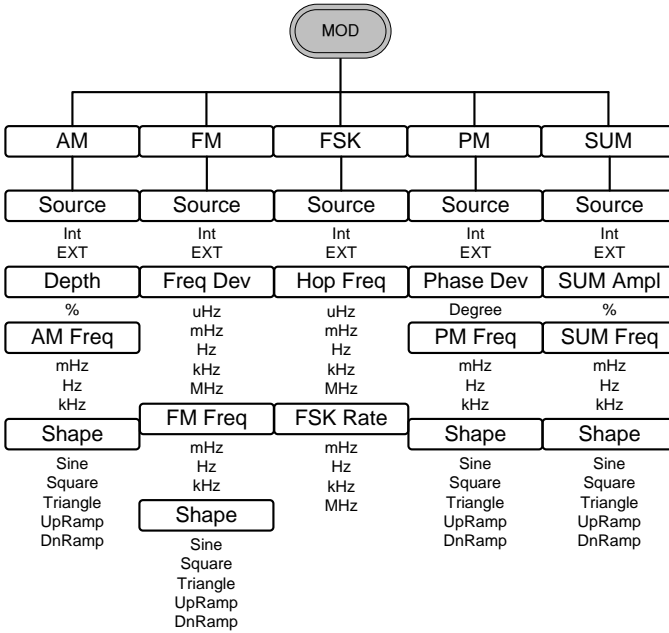

SWEEP

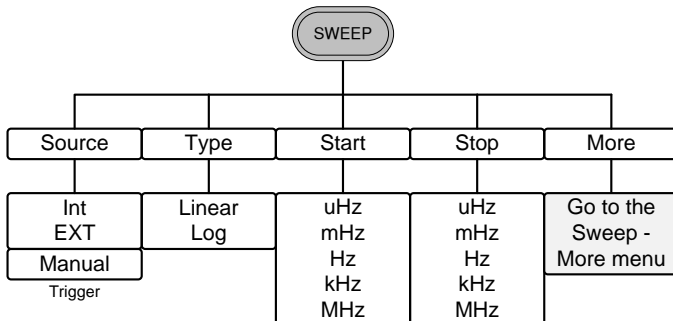

SWEEP- More

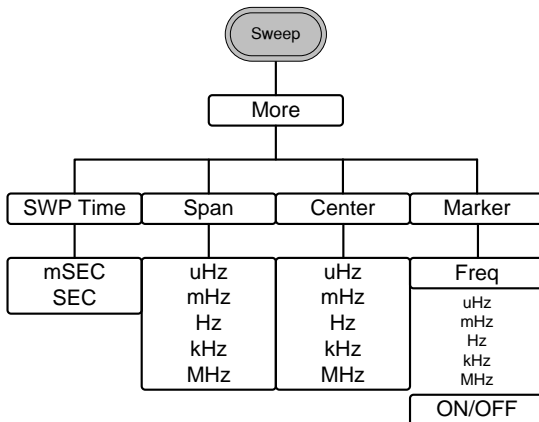

Burst- N Cycle

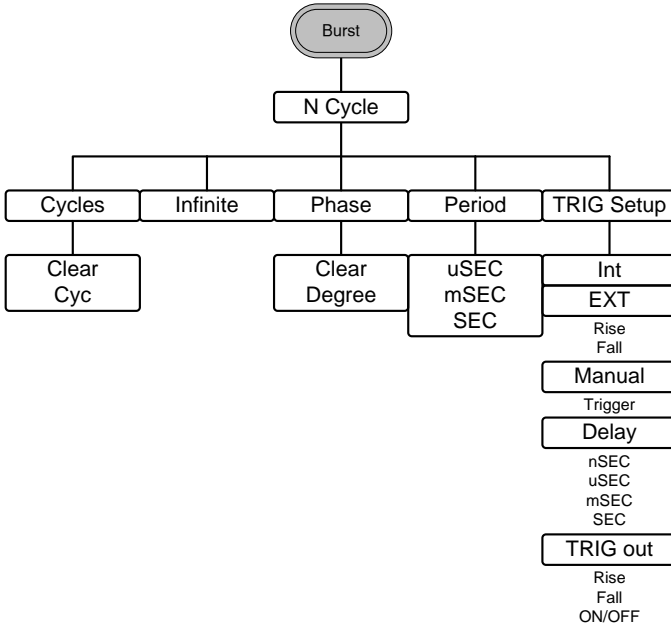

Burst – Gate

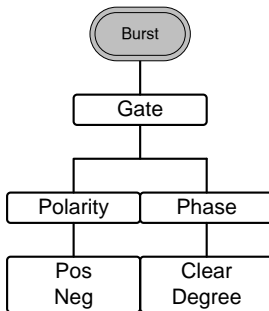

UTIL

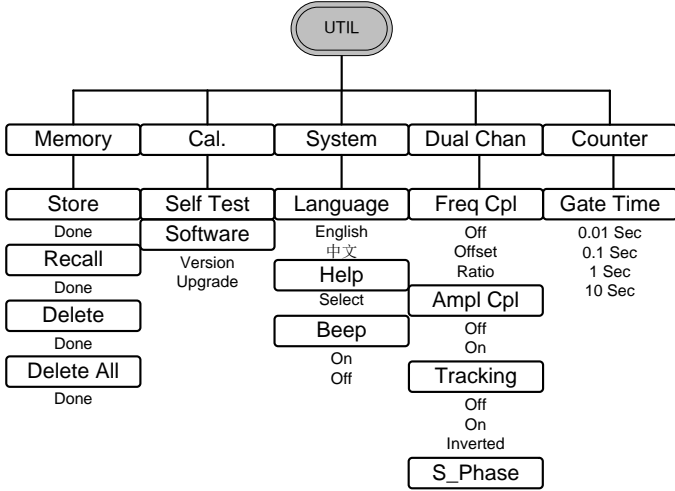

CH1/CH2

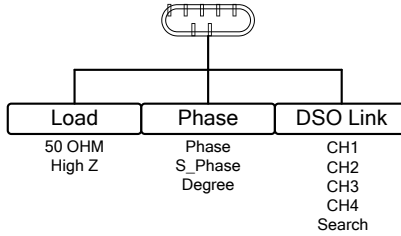

Default Settings

The Preset key is used to restore the default panel settings.



Output Settings	Function	Sine Wave
	Frequency	1kHz
	Amplitude	3.000 Vpp
	Offset	0.00V dc
	Output units	Vpp
	Output terminal	50Ω

Modulation (AM/FM/FSK/ PM/SUM)	Carrier wave	1kHz sine wave
	Modulation wave	100Hz sine wave
	AM depth	100%
	FM deviation	100Hz
	FSK hop frequency	100Hz
	FSK frequency	10Hz
	PM phase deviation	180°
	SUM amplitude	50%
	Modem status	Off

Sweep	Start/Stop frequency	100Hz/1kHz
	Sweep time	1s
	Sweep type	Linear
	Sweep status	Off

Burst	Burst frequency	1kHz
	Ncycle	1
	Burst period	10ms
	Burst starting phase	0°
	Burst status	Off
System Settings	Power off signal	On
	Display mode	On
	Error queue	Cleared
	Memory settings	No change
	Output	Off
Trigger	Trigger source	Internal (immediate)
Calibration	Calibration Menu	Restricted

AFG-2225 Specifications

The specifications apply when the function generator is powered on for at least 30 minutes under +18°C~+28°C.

AFG-2225 models		CH1	CH2
Waveforms		Sine, Square, Ramp, Pulse, Noise, ARB	
Arbitrary Functions (1)			
	Sample Rate	120 MSa/s	
	Repetition Rate	60MHz	
	Waveform	4k points	
	Length		
	Amplitude	10 bits	
	Resolution		
	Non-Volatile Memory	4k points	
Frequency Characteristics			
Range	Sine	1uHz~25MHz	
	Square	1uHz~25MHz	
	Ramp	1MHz	
Resolution		1uHz	
Accuracy	Stability	±20 ppm	
	Aging	±1 ppm, per 1 year	
	Tolerance	≤1 mHz	
Output Characteristics			
Amplitude	Range	1mVpp to 10 Vpp (into 50Ω)	
		2mVpp to 20 Vpp (open-circuit)	
		1mVpp to 5 Vpp (into 50Ω) for 20MHz-25MHz	
		2mVpp to 10 Vpp (open-circuit) for 20MHz-25MHz	
	Accuracy	±2% of setting ±1 mVpp (at 1 kHz/into 50Ω without DC offset)	
	Resolution	1mV or 3 digits	
	Flatness	±1% (0.1dB) ≤100kHz ±3% (0.3 dB) ≤5MHz ±5% (0.4 dB) ≤12MHz ±10%(0.9dB) ≤25MHz (sine wave relative to 1kHz/into 50Ω)	
	Units	Vpp, Vrms, dBm	
Offset	Range	±5 Vpk ac +dc (into 50Ω)	
		±10Vpk ac +dc (Open circuit)	
		±2.5 Vpk ac +dc (into 50Ω) for 20MHz-25MHz ±5Vpk ac +dc (Open circuit) for 20MHz-25MHz	
	Accuracy	2% of setting + 10mV+ 0.5% of amplitude	
Waveform Output	Impedance	50Ω typical (fixed)	
		> 10MΩ (output disabled)	
	Protection	Short-circuit protected Overload relay automatically disables main output	

Sine wave			
Characteristics			
Harmonic distortion	≤-55 dBc	DC ~ 200kHz, Ampl > 0.1Vpp	
	≤-50 dBc	200kHz ~ 1MHz, Ampl > 0.1Vpp	
	≤-35 dBc	1MHz ~ 5MHz, Ampl > 0.1Vpp	
	≤-30 dBc	5MHz ~ 25MHz, Ampl > 0.1Vpp	
Square wave			
Characteristics			
Rise/Fall Time	≤25ns at maximum output. (into 50 Ω load)		
Overshoot	5%		
Asymmetry	1% of period +5 ns		
Variable duty Cycle	1.0% to 99.0% ≤100kHz		
	10% to 90% ≤ 1MHz		
	50% ≤ 25MHz		
Ramp Characteristics			
Linearity	< 0.1% of peak output		
Variable Symmetry	0% to 100% (0.1% Resolution)		
Pulse Characteristics			
Period	40ns~2000s		
Pulse Width (2)	20ns~1999.9s		
Overshoot	<5%		
Accuracy	0.1%+20ns		
Jitter	20ppm +10ns		
AM Modulation			
Carrier Waveforms	Sine, Square, Ramp, Pulse, Arb	Sine, Square, Ramp, Pulse, Arb	
Modulating Waveforms	Sine, Square, Triangle, Upramp, Dnramp	Sine, Square, Triangle, Upramp, Dnramp	
Modulating Frequency	2mHz to 20kHz (Int)	2mHz to 20kHz (Int)	
	DC to 20kHz (Ext)	DC to 20kHz (Ext)	
Depth	0% to 120.0%		
Source	Internal / External		Internal / External
FM Modulation			
Carrier Waveforms	Sine, Square, Ramp,	Sine, Square, Ramp,	
Modulating Waveforms	Sine, Square, Triangle, Upramp, Dnramp	Sine, Square, Triangle, Upramp, Dnramp	
Modulating Frequency	2mHz to 20kHz (Int)	2mHz to 20kHz (Int)	
	DC to 20kHz (Ext)	DC to 20kHz (Ext)	
Peak Deviation	DC to Max Frequency		DC to Max Frequency
Source	Internal / External		Internal / External
Sweep			
Waveforms	Sine, Square, Ramp,	Sine, Square, Ramp,	
Type	Linear or Logarithmic	Linear or Logarithmic	
Start/Stop Freq	1uHz to Max Frequency	1uHz to Max Frequency	

	Sweep Time	1ms to 500s	1ms to 500s
	Source	Internal / External/Manual	Internal / External/Manual
FSK			
	Carrier Waveforms	Sine, Square, Ramp,Pulse	Sine, Square, Ramp,Pulse
	Modulating Waveforms	50% duty cycle square	50% duty cycle square
	Modulation Rate	2mHz to 100 kHz (INT) DC to 100 kHz(EXT)	2mHz to 100 kHz (INT) DC to 100 kHz(EXT)
	Frequency Range	1uHz to Max Frequency	1uHz to Max Frequency
	Source	Internal / External	Internal / External
PM			
	Carrier Waveforms	Sine, Square, Ramp	Sine, Square, Ramp
	Modulating Waveforms	Sine, Square, Triangle, Up ramp, Dn ramp	Sine, Square, Triangle, Up ramp, Dn ramp
	Modulation Frequency	2mHz to 20kHz (Int) DC to 20kHz (Ext)	2mHz to 20kHz (Int) DC to 20kHz (Ext)
	Phase deviation	0° to 360°	0° to 360°
	Source	Internal / External	Internal / External
SUM			
	Carrier Waveforms	Sine, Square, Ramp,Pulse,Noise	Sine, Square, Ramp,Pulse,Noise
	Modulating Waveforms	Sine, Square, Triangle, Up ramp,Dn ramp	Sine, Square, Triangle, Up ramp,Dn ramp
	Modulation Frequency	2mHz to 20kHz (Int) DC to 20kHz (Ext)	2mHz to 20kHz (Int) DC to 20kHz (Ext)
	SUM Depth	0% to 100.0%	0% to 100.0%
	Source	Internal / External	Internal / External
External Trigger Input			
	Type	For FSK, Burst, Sweep	
	Input Level	TTL Compatibility	
	Slope	Rising or Falling(Selectable)	
	Pulse Width	>100ns	
	Input Impedance	10k Ω , DC coupled	
External Modulation Input			
	Type	For AM, FM, PM, SUM	
	Voltage Range	\pm 5V full scale	
	Input Impedance	10k Ω	
	Frequency	DC to 20kHz	
Trigger Output			
	Type	For Burst, Sweep, Arb	
	Level	TTL Compatible into 50 Ω	
	Pulse Width	>450ns	
	Maximum Rate	1MHz	
	Fan-out	\geq 4 TTL Load	
	Impedance	50 Ω Typical	
Dual Channel Function			

	Phase (3)	-180° ~180°	-180° ~ 180°
		Synchronize phase	Synchronize phase
	Track	CH2=CH1	CH1=CH2
	Coupling	Frequency(Ratio or Difference)	Frequency(Ratio or Difference)
		Amplitude & DC Offset	Amplitude & DC Offset
	Dsolink	√	√
Burst	Waveforms	Sine, Square, Ramp,Arb	Sine, Square, Ramp,Arb
	Frequency	1uHz~15 MHz(Sine) 1uHz~15 MHz (Squa) 1uHz~1 MHz (Ramp)	1uHz~15 MHz(Sine) 1uHz~15 MHz (Squa) 1uHz~1 MHz (Ramp)
	Burst Count	1 to 65535 cycles or Infinite	1 to 65535 cycles or Infinite
	Start/Stop Phase	-360 to +360	-360 to +360
	Internal Period	1ms to 500s	1ms to 500s
	Gate Source	External Trigger	External Trigger
	Trigger Source	Single, External or Internal Rate	Single, External or Internal Rate
Trigger Delay	N-Cycle, Infinite	0s to 655350ns	0s to 655350ns
Frequency Counter	Range	5Hz to 150MHz	
	Accuracy	Time Base accuracy±1count	
	Time Base	±20ppm (23 °C ±5 °C) after 30 minutes warm up	
	Resolution	The maximum resolution is: 100nHz for 1Hz, 0.1Hz for 100MHz.	
	Input Impedance	1kΩ/1pf	
	Sensitivity	35mVrms ~ 30Vms (5Hz to 150MHz)	
Save/Recall		10 Groups of Setting Memories	
Interface		USB (Host&Device)	
Display		TFT	
General Specifications	Power Source	AC100~240V, 50~60Hz	
	Power Consumption	25 W (Max)	
	Operating Environment	Temperature to satisfy the specification : 18 ~ 28 °C	
		Operating temperature : 0 ~ 40 °C	
		Relative Humidity: < 80%, 0 ~ 40 °C	
		Installation category : CAT II	
	Operating Altitude	2000 Meters	
	Storage Temperature	-10~70 °C, Humidity: ≤70%	
	Dimensions (WxHxD)	266(W) x 107(H) x 293(D) mm	
	Weight	Approx. 2.5kg	
	Accessories	GTL-101x 2	

Quick Start Guide ×1
CD (user manual + software) ×1
Power cord×1

- (1) Filter bandwidth 20MHz.-3dB
- (2) Pulse amplitude will decrease when pulse width is <50ns
- (3) Square and Pulse can not be change, Phase is 0°

EC Declaration of Conformity

We

GOOD WILL INSTRUMENT CO., LTD.

declare that the below mentioned product

Type of Product: 20MHz True Dual Channel Arbitrary Function Generator

Model Number: AFG-2225

is herewith confirmed to comply with the requirements set out in the Council Directive on the Approximation of the Law of Member States relating to Electromagnetic Compatibility (2014/30/EU) and Low Voltage Directive (2014/35/EU).

For the evaluation regarding the Electromagnetic Compatibility and Low Voltage Directive, the following standards were applied:

Ⓢ EMC	
EN 61326-1:	Electrical equipment for measurement, control and laboratory use -- EMC requirements (2013)
EN 61326-2-1:	
Conducted & Radiated Emission EN 55011: 2009+A1: 2010	Electrical Fast Transients EN 61000-4-4: 2012
Current Harmonics EN 61000-3-2: 2014	Surge Immunity EN 61000-4-5: 2006
Voltage Fluctuations EN 61000-3-3: 2013	Conducted Susceptibility EN 61000-4-6: 2014
Electrostatic Discharge EN 61000-4-2: 2009	Power Frequency Magnetic Field EN 61000-4-8: 2010
Radiated Immunity EN 61000-4-3: 2006+A1: 2008+A2: 2010	Voltage Dip/ Interruption EN 61000-4-11: 2004
Low Voltage Equipment Directive 2014/35/EU	
Safety Requirements	IEC 61010-1: 2010 (Third Edition)

GOOD WILL INSTRUMENT CO., LTD.

No. 7-1, Jhongsing Road, Tucheng Dist., New Taipei City 236, Taiwan

Tel: +886-2-2268-0389

Fax: +866-2-2268-0639

Web: www.gwinstek.com

Email: marketing@goodwill.com.tw

GOOD WILL INSTRUMENT (SUZHOU) CO., LTD.

No. 521, Zhujiang Road, Snd, Suzhou Jiangsu 215011, China

Tel: +86-512-6661-7177

Fax: +86-512-6661-7277

Web: www.instek.com.cn

Email: marketing@instek.com.cn

GOOD WILL INSTRUMENT EURO B.V.

De Run 5427A, 5504DG Veldhoven, The Netherlands

Tel: +31(0)40-2557790

Fax: +31(0)40-2541194

Email: sales@gw-instek.eu